

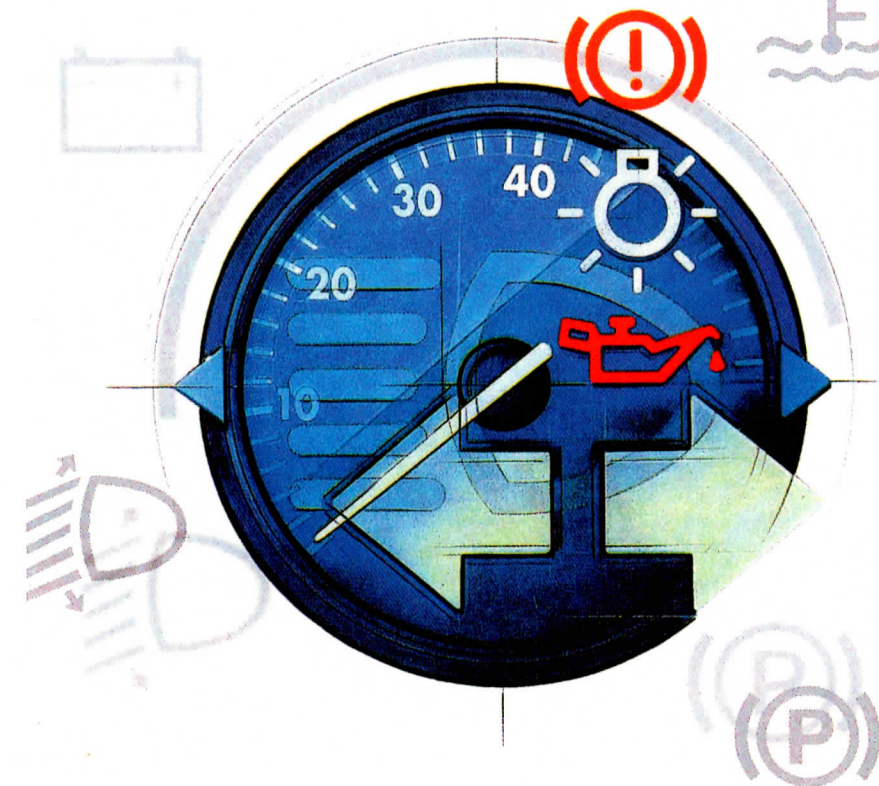

Multivan Caravelle Transporter

*Controls and
Equipment - Part 2*



CONTENTS

AIR CONDITIONING

Heating and ventilation	
– Passenger models	2
– Commercial models	10
Air conditioner	
– Passenger models	15
– Commercial models	25
Climatronic	32
Auxiliary heater	41
Additional water heater	47

Heating and ventilation (Passenger models)

You can adjust the interior temperature of your vehicle to suit your requirements using the heating and ventilation system. To achieve this, the interior is either cooled or heated using the following procedure.

Please note that the desired interior temperature cannot be any lower than the ambient temperature.

The best possible heating performance and quick defrosting of the windscreen can only be achieved once the engine has reached its normal operating temperature.

Warning

For road safety it is important that all windows are free of ice, snow and mist. Only then can clear vision be guaranteed.

You should, therefore, familiarise yourself with the correct operation of the heating and ventilation system as well as removing dampness and frost from the windows.

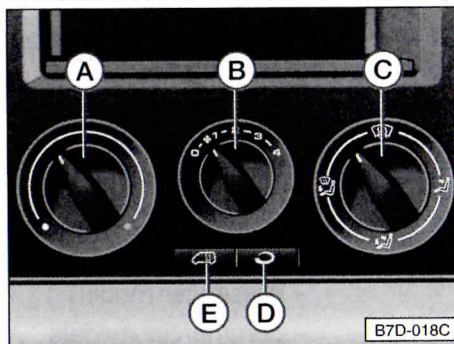

Controls

In the instrument panel (Front seat area)

- A – Rotary regulator – temperature control
- B – Rotary switch – blower
- C – Rotary regulator – air distribution
- D – Button – air recirculation
- E – Switch over button*

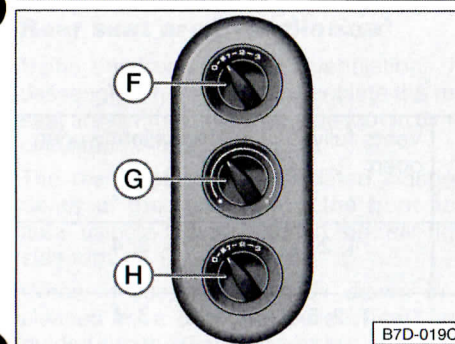

Controls in rear seat area

- F – Rotary switch – blower for rear seat area ventilation*
- G – Rotary regulator – temperature control for rear seat area heating*
- H – Rotary switch – blower for rear seat area heating*

The controls in the rear seat area are in the pillar trim opposite the sliding door and can be operated by the passengers in the rear.

On some model versions, the controls are located in the lower area of the pillar trim or next to the sliding door.

Heating and ventilation

● To ensure that the heating and ventilation can work properly, the air inlet in front of the windscreen should be kept free of ice, snow and leaves.

Rotary regulator A – Temperature selector

(Front seat area)

Clockwise – increases heat output
Anti-clockwise – decreases heat output

The rotary switch can be adjusted to suit your requirements.

The heating effect is dependent on the coolant temperature – full heating therefore only possible with the engine at operating temperature.

Rotary switch B – Blower

(Front seat area)





Air throughput can be adjusted in four stages with the blower control. When driving slowly the blower should always be running at a low speed.

On vehicles with a dust and pollen filter* dust, pollen, soot etc. will be held back by the filter regardless of the position of blower switch **B**.

In position 0, the air supply and blower are switched off. This prevents contaminated air entering the vehicle interior. However as the windows will then mist up the air supply should only be cut off briefly.

Rotary regulator C – Air distribution

(Front seat area)

Regulator to symbol...	Air vent open...	Vents fully open	Vents slightly open
	...at windscreen	1, 2	3, 4
	...at windscreen and in the footwell	1, 2, 5	3, 4
	...to the upper body	3, 4	—
	...in the footwell	5	1, 2, 3, 4

The rotary switch can be adjusted to suit your requirements.

For vent layout, see next page 7.

Button D – Air recirculation

Air recirculation is selected by pressing this button. A warning lamp lights up in the button.

After switching on the blowers for the front and rear seat areas* operate in the air recirculation mode.

Air recirculation is switched off by pressing the button again. The warning lamp then goes out.

The air recirculation function prevents strong outside smells entering the vehicle, for example when driving through a tunnel or standing in a traffic jam.

Air recirculation can also be selected if the vehicle is to be heated quickly. In this mode, air is drawn in from the vehicle interior and heated.

For reasons of safety, air recirculation is **not** possible if rotary regulator **C** is turned to the following position: .. 

Warning

You should not use the air recirculation mode for an extended period of time, as no fresh air is drawn in from outside and the windows could mist up.

Button E – Switch over button*

The controls in the front seat area are switched open by pressing this button. This mode is indicated by the warning lamp lighting up in the button.

The controls are switched off by pressing the button again. The warning lamp in the button will switch off. In this mode, the rear seat area heating* or the rear seat area ventilation cannot be operated.

Note

The buttons **D** and **E** can also be pressed in combination.

Rear seat area ventilation*

Using the front seat area ventilation, the passengers in the rear can ventilate the rear seat area with air from outside (not in air recirculation mode).

The rear seat area is ventilated independently of the ventilation in the front seat area, using a blower fitted in the rear right side trim.

When in use, the fresh air drawn in is cleaned by a dust and pollen filter* and guided into the rear seat area by vents in the roof.

At least one vent in the roof must be open when the blower is functioning as the blower will otherwise switch off due to overheating.

To ensure that the rear seat area ventilation can work properly, the air inlet in front of the windscreen should be kept free of ice, snow and leaves.

Switching on

Press the switch over button **E** and turn the blower switch **F** to blower levels 1 to 3.

Switching off

Press the switch over button **E** again or turn the blower switch **F** to blower level 0.

Rotary switch F – Blower

Air throughput can be adjusted in three stages.

Roof outlets

The roof outlets can be closed or opened separately. They can also be adjusted by repositioning the outlet grille.

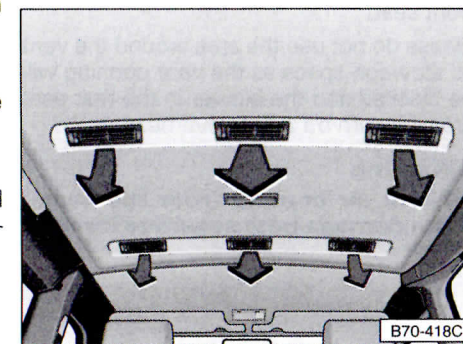
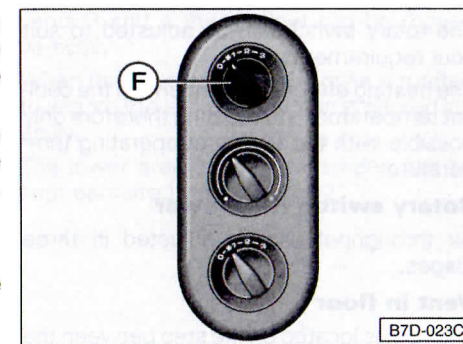
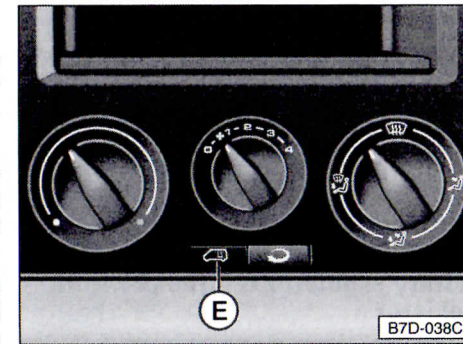

Rear seat area heating*

The rear seat area is heated independently of the standard vehicle heating in the front seat area. The air in the rear seat area is heated via the air recirculation mode.

The rear seat area heating will only function when the switch over button **E** has been pressed and when the blower switch **H** is in blower level 1 to 3.

Rotary regulator G - Temperature selector

Clockwise - increases heat output
Anti-clockwise - decreases heat output

The rotary switch can be adjusted to suit your requirements.

The heating effect is dependent on the coolant temperature - full heating therefore only possible with the engine at operating temperature.

Rotary switch H - Blower

Air throughput can be adjusted in three stages.

Vent in floor

The vent is located on the step between the front and rear seat areas behind the right front seat.

Please do not use the area around the vent as stowage space as the vent opening will be blocked and the blower in the rear seat area will turn off due to overheating.

Warning

Warm air coming from the vent can damage heat sensitive items.

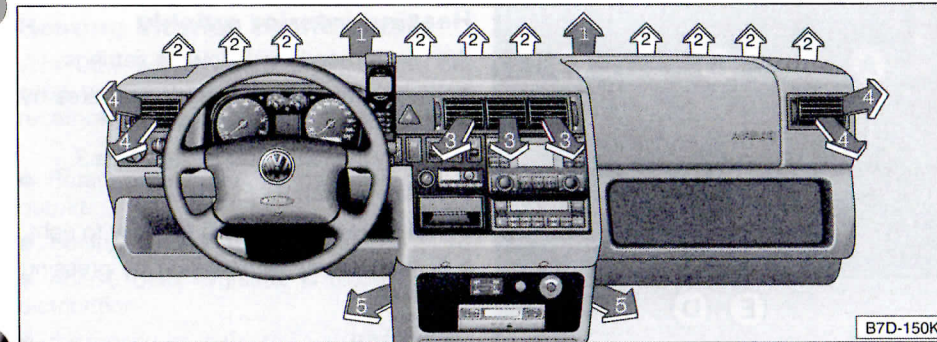
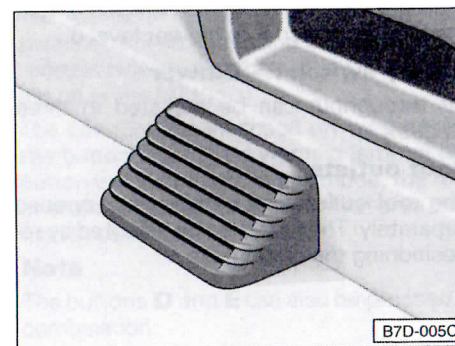
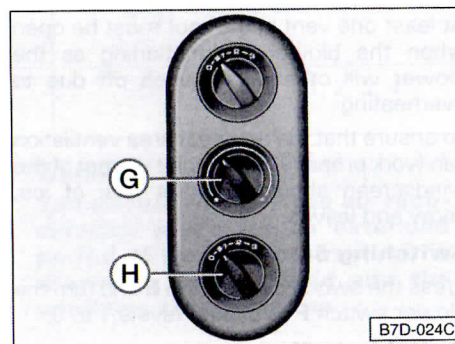
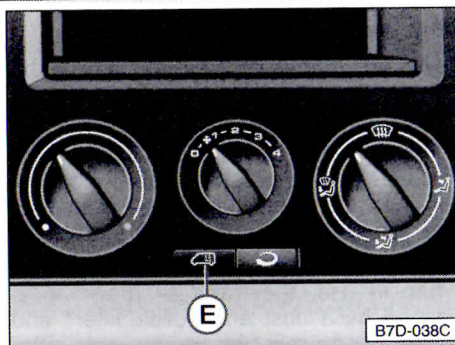

Air vents

Depending on the position of the rotary regulator **A** heated or unheated fresh air flows from vents 1, 2, 4 and 5 in the front seat area when open.

Only unheated fresh air will flow from vents 3.

On vehicles with a 111 kW engine, heated fresh air can also flow from vents 3.

The vents are controlled by the rotary regulator **C**.

The vents 3 and 4 can be opened and closed separately:

- vent opened
side knurled wheel to ○
- vent closed
side knurled wheel to ●

By swinging the complete outlet grille of vents 3 and 4 the air flow can be moved vertically.

When the knurled disc in the grille is rotated to and fro the air flow direction is altered laterally.

The lower area of the windscreen can be kept demisted via the vents 2.

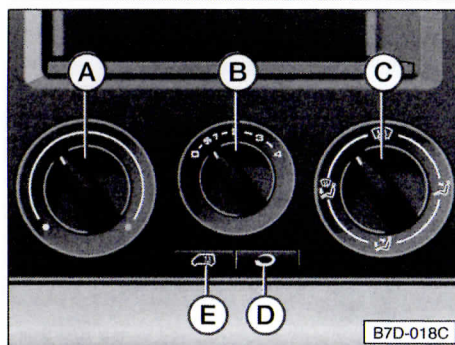

Defrosting windscreen and side windows

We recommend the following settings:

- Rotary regulator **A** turned fully to right.
- Rotary switch **B** to stage 3.
- Rotary regulator **C** to 
- Vents 3 closed
- Adjust vents 4 so that additional warm air can be directed to the side windows.

Demisting windscreen and side windows

When the windows mist up due to high air humidity, e.g. when it is raining, we recommend the following settings:

- Rotary regulator **A** at the desired heat output.
- Rotary switch **B** to stage 2 or 3.
- Rotary regulator **C** to 
- Vents 3 closed.
- Additional warm air can be directed to the side windows via vents 4.

Heating interior quickly



We recommend the following settings:

- Switch on controls in rear seat area by pressing the switch over button **E***.
- Rotary switch **B** and **H*** to stage 3.
- Rotary switch **F*** to stage 0.
- Rotary regulator **A** and **G*** fully to right.
- Switch on air recirculation by pressing button **D**.

Warning

You should not use the air recirculation mode for an extended period of time, as no fresh air is drawn in from outside and the windows could mist up.

Note information on recirculating air operation on page 4.

- Rotary regulator **C** to 
- If windscreen is misted over, rotary regulator **C** to 

If the rotary regulator **C** is in this position **no** air recirculation is possible.

- Vents 3 closed.
- Vents 4 set as required.



Heating interior comfortably

When the windows are clear and the desired temperature has been reached we recommend the following settings:

- Rotary regulator **A** at the desired heat output.
- Rotary switch **B** to desired stage.
- Adjust rotary regulator **C** to desired air distribution
- If windscreen is misted over, rotary regulator **C** to 
- Switch off air recirculation by pressing button **D**.
- Switch off controls in rear seat area by pressing the switch over button **E***.
- Vents 3 closed.
- Set vents 4 as required.

Ventilation (fresh air operation)

With the following settings, unheated fresh air flows from vents 3 and 4 and in roof:

- Switch on controls in rear seat area by pressing the switch over button **E***.
- Switch off air recirculation by pressing button **D**.
- Rotary switch **H*** to stage 0.
- Rotary regulator **A** anti-clockwise to the stop
- Rotary switch **B** and **F*** to desired stage.
- Rotary regulator **C** to 
- If windscreen is misted over, rotary regulator **C** to 
- If required, regulator **C** can be turned to another position.
- Vents 3 and 4 in roof open.

General notes

- In order to prevent the windows from misting up, you should always set rotary switch **B** to a low level when driving at low speeds and set rotary regulator **C** to the following position: 
- The stale air escapes through openings in the luggage compartment side panels. Therefore when loading the luggage compartment ensure that the openings are not covered.

Heating and ventilation (Commercial models)

You can adjust the interior temperature of your vehicle to suit your requirements using the heating and ventilation system. To achieve this, the interior is either cooled or heated using the following procedure.

Please note that the desired interior temperature cannot be any lower than the ambient temperature.

The best possible heating performance and quick defrosting of the windscreen can only be achieved once the engine has reached its normal operating temperature.

Warning

For road safety it is important that all windows are free of ice, snow and mist. Only then can clear vision be guaranteed.

You should, therefore, familiarise yourself with the correct operation of the heating and ventilation system as well as removing dampness and frost from the windows.

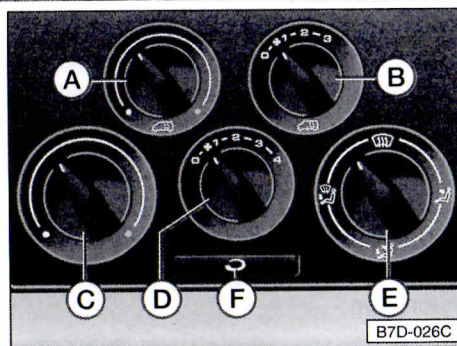

Controls

- A – Rotary regulator – temperature control for additional heater*
- B – Rotary switch – blower for additional heater*
- C – Temperature control rotary regulator
- D – Rotary switch – blower
- E – Rotary regulator – air distribution
- F – Button – air recirculation

Heating and ventilation

● To ensure that the heating and ventilation can work properly, the air inlet in front of the windscreen should be kept free of ice, snow and leaves.

Rotary regulator C – Temperature selector

Clockwise – increases heat output
Anti-clockwise – decreases heat output

The rotary switch can be adjusted to suit your requirements.

The heating effect is dependent on the coolant temperature – full heating therefore only possible with the engine at operating temperature.

Rotary switch D – Blower

Air throughput can be adjusted in four stages with the blower control. When driving slowly the blower should always be running at a low speed.

On vehicles with a dust and pollen filter* dust, pollen, soot etc. will be held back by the filter regardless of the position of blower switch **D**.

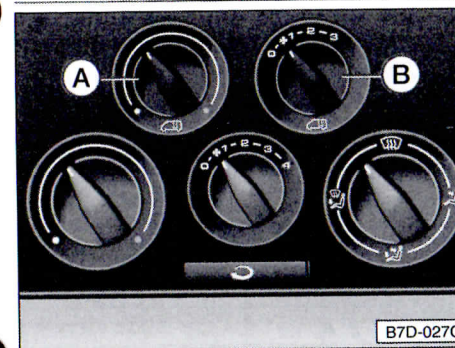

Additional heater*

With the additional heater the air in the load area can be heated. However, there is no fresh air input as the heat exchanger only works in recirculating operation.

Rotary regulator A – Temperature selector

Clockwise – increases heat output
Anti-clockwise – decreases heat output

The rotary switch can be adjusted to suit your requirements.

The heating effect is dependent on the coolant temperature – full heating therefore only possible with the engine at operating temperature.

Rotary switch B – blower

Air throughput can be adjusted in three stages.

Vent





The vent is located on the step between the front seat area and the load area.

Please do not use the area around the vent as stowage space as the vent opening will be blocked and the blower will turn off due to overheating.

Warning

Warm air coming from the vent can damage heat sensitive items.

Rotary reg. E – Air distribution

Regulator to symbol...	Air vent open...	Vents fully open	Vents slightly open
	...at windscreen	1, 2	3, 4
	...at windscreen and in the footwell	1, 2, 5	3, 4
	...to the upper body	3, 4	—
	...in the footwell	5	1, 2, 3, 4

The rotary switch can be adjusted to suit your requirements.

For vent layout, see next page.

Button F – Air recirculation

Air recirculation is selected by pressing this button. A warning lamp lights up in the button.

In this mode, air is drawn in from the vehicle interior and recirculated.

Air recirculation is switched off by pressing the button again. The warning lamp then goes out.

The air recirculation function prevents strong outside smells entering the vehicle, for example when driving through a tunnel or standing in a traffic jam.

Air recirculation can also be selected if the vehicle is to be heated quickly. In this mode, air is drawn in from the vehicle interior and heated.

Warning

You should not use the air recirculation mode for an extended period of time, as no fresh air is drawn in from outside and the windows could mist up.

For reasons of safety, air recirculation is **not** possible if rotary regulator **E** is turned to the following position: . . .

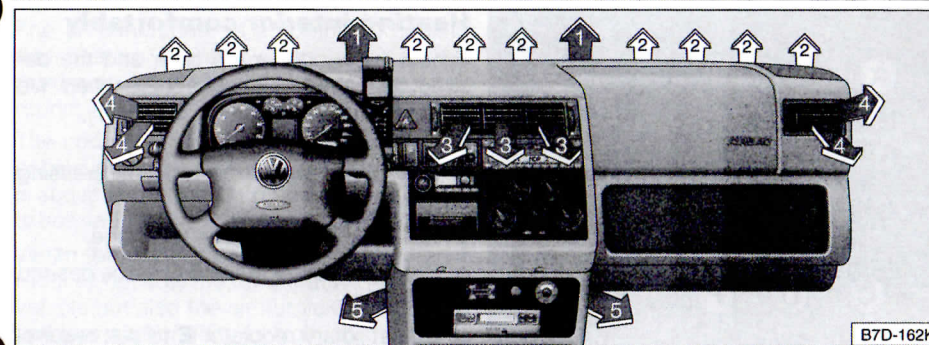

Air vents

Depending on the position of the rotary regulator **C** heated or unheated fresh air flows from vents 1, 2, 4 and 5 in the driver's compartment (front) when open.

Only unheated fresh air will flow from vents 3.

The air flow is switched to the appropriate vents using rotary regulator **E**.

The vents 3 and 4 can be opened and closed separately:

vent opened side knurled wheel to **O**

vent closed side knurled wheel to **●**

By swinging the complete outlet grille of vents 3 and 4 the air flow can be moved vertically.

When the knurled disc in the grille is rotated to and fro the air flow direction is altered laterally.

The lower area of the windscreen can be kept demisted via the vents 2.

Defrosting windscreen and side windows

We recommend the following settings:

- Rotary switch **D** to stage 3.
- Rotary regulator **C** turned fully to right.
- Rotary regulator **E** to 
- Vents 3 closed
- Adjust vents 4 so that additional warm air can be directed to the side windows.

Demisting windscreen and side windows

When the windows mist up due to high air humidity, e.g. when it is raining, we recommend the following settings:

- Rotary switch **D** to stage 2 or 3.
- Rotary regulator **C** at the desired heat output.
- Rotary regulator **E** to 
- Vents 3 closed.
- Additional warm air can be directed to the side windows via vents 4.

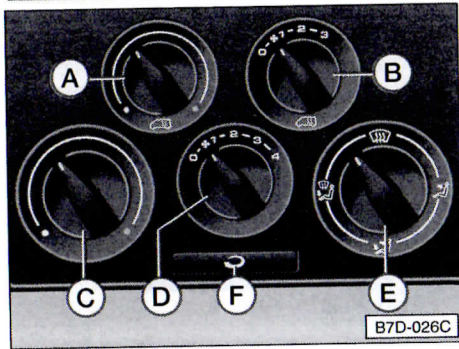

Heating interior comfortably

When the windows are clear and the desired temperature has been reached we recommend the following settings:



- Switch off air recirculation by pressing button **F**.
- Rotary switch **B** to desired stage.
- Rotary regulator **A*** and **C** at the desired heat output.
- Adjust rotary regulator **E** to suit requirements for air distribution
- When windscreen misted up set rotary regulator **E** to 
- Vents 3 closed.
- Set vents 4 as required.

General notes

- The stale air escapes through ventilation slots in the load area side panel trim. Therefore, these slots should not be covered. On vehicles with a full-width partition and on the Pick-up and Double Cab models the stale air escapes through slots in the driver's and front passenger doors.
- In order to prevent the windows from misting up, you should always set rotary switch **D** to a low level when driving at low speeds and set rotary regulator **E** to the following position: 

Ventilation (fresh air operation)



With the following settings, unheated fresh air flows from vents 3 and 4:

- Rotary switch **B** to stage 0.
 - Rotary switch **D** to desired stage.
 - Rotary regulator **A*** and **C** fully to the left. 
 - Rotary regulator **E** to 
 - When windscreen misted up set rotary regulator **E** to 
- If required, regulator **E** can be turned to another position.
- Vents 3 and 4 open.

Heating interior quickly

- Rotary switch **B*** and **D** to stage 3.
- Rotary regulator **A*** and **C** fully to right.
- Switch on air recirculation by pressing button **F**.

Note information on recirculating air operation on page 12.

- Rotary regulator **E** to 
 - When windscreen misted up set rotary regulator **E** to 
- If the rotary regulator **E** is in this position **no** air recirculation is possible.
- Vents 3 closed.
 - Vents 4 set as required.

Air conditioner* (Passenger models)

The air conditioner is a combined cooling and heating system which provides the maximum possible comfort all the year round.

The cooling system only works when the engine is running, the ambient temperature is above about + 5°C and the blower speed is between 1 and 4 on rotary switch **B**.

When the cooling system is switched on it reduces not only the temperature inside the vehicle but also the air humidity. When the ambient air humidity is high, this not only makes the vehicle occupants feel more comfortable, even in winter, but also prevents the windows from steaming up.

The best possible heating performance and quick defrosting of the windscreen can only be achieved once the engine has reached its normal operating temperature.

Warning

For road safety it is important that all windows are free of ice, snow and mist. Only then can clear vision be guaranteed.

You should, therefore, familiarise yourself with the correct operation of the heating and ventilation system, the removal of dampness and frost from the windows as well as the cooling system.

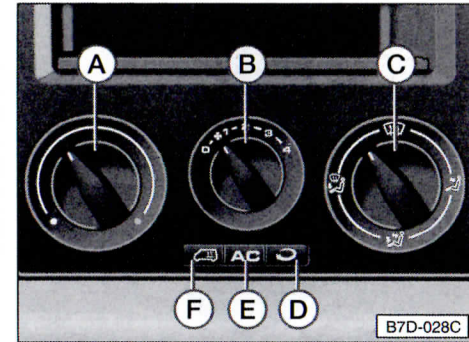

Controls

In the instrument panel (Front seat area)

- A – Rotary regulator – temperature control
- B – Rotary switch – blower
- C – Rotary regulator – air distribution
- D – Button – air recirculation
- E – Button – air conditioner on/off
- F – Switch over button*

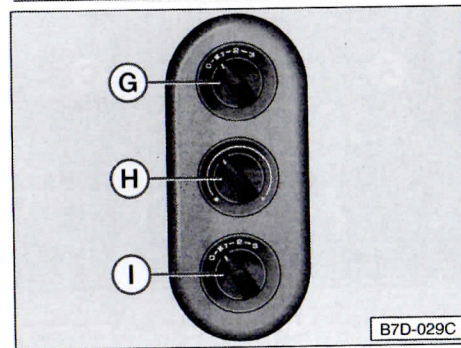

Controls in rear seat area

- G – Rotary switch – blower for rear seat area ventilation*
- H – Rotary regulator – temperature control for rear seat area heating*
- I – Rotary switch – blower for rear seat area heating*

The controls in the rear seat area are in the pillar trim opposite the sliding door and can be operated by the passengers in the rear. On some model versions, the controls are located in the lower area of the pillar trim or next to the sliding door.

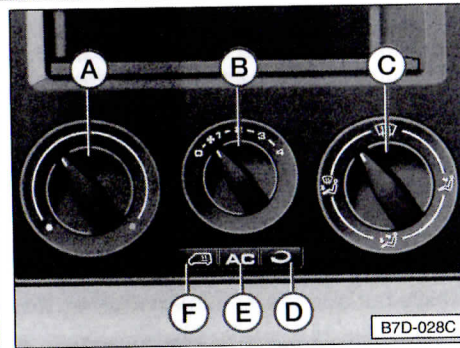

Air conditioner

Rotary regulator A – Temperature selector

Clockwise – increases heat output
 Anti-clockwise – decreases heat output
 When the **air conditioner** is switched on, turning the switch anti-clockwise increases the cooling.

The rotary switch can be adjusted to suit your requirements.

The heating effect is dependent on the coolant temperature – full heating therefore only possible with the engine at operating temperature.





Rotary switch B – Blower

Air throughput can be adjusted in four stages with the blower control. When driving slowly the blower should always be running at a low speed.

On vehicles with a dust and pollen filter* dust, pollen, soot etc. will be held back by the filter regardless of the position of blower switch **B**.

In position 0, the blower and air conditioner are switched off. To prevent contaminated air (smells) entering the vehicle interior, press button **D** (air recirculation).

Rotary regulator C – Air distribution

Regulator to symbol...	Air vent open...	Vents fully open	Vents slightly open
	...at windscreen	1, 2	3, 4
	...at windscreen and in the footwell	1, 2, 5	3, 4
	...to the upper body	3, 4	—
	...in the footwell	5	1, 2, 3, 4

The rotary switch can be adjusted to suit your requirements.

For vent layout, see next page 21.

Button D – Air recirculation

Air recirculation is selected by pressing this button. A warning lamp lights up in the button.

After switching on the blowers for the front and rear seat areas* operate in the air recirculation mode.

Air recirculation is switched off by pressing the button again. The warning lamp then goes out.

The air recirculation function prevents strong outside smells entering the vehicle, for example when driving through a tunnel or standing in a traffic jam.

Air recirculation can also be selected if the vehicle is to be heated or cooled quickly. In this mode, air is drawn in from the vehicle interior and heated or cooled.

Warning

You should not use the air recirculation mode for an extended period of time, as no fresh air is drawn in and the windows could mist up.

Smoking should be avoided when air recirculation is selected, as the smoke drawn in from the vehicle interior deposits on the evaporator of the air conditioner. This leads to permanent odours when the air conditioner is in operation. These can only be eliminated by exchanging the evaporator, which is time-consuming and expensive.

Note

Buttons **D**, **E** and **F** can be used in combination.

For reasons of safety, air recirculation is **not** possible if rotary regulator **C** is turned to the following position: . .



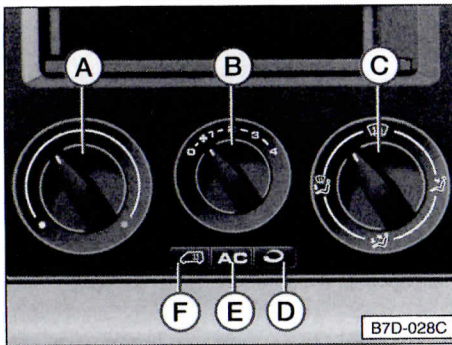

Button E - Air conditioner on/off

The system is switched on by pressing this button. A warning lamp lights up in the button pressed.

The system is switched off by pressing the button again. The warning lamp then goes out.

Note

Buttons **D**, **E** and **F** can be used in combination.

Button F - Switch over button*

The controls in the front seat area are switched open by pressing this button. This mode is indicated by the warning lamp lighting up in the button.

The controls are switched off by pressing the button again. The warning lamp in the button will switch off. In this mode, the rear seat area heating* or the rear seat area ventilation cannot be operated.

Note

Buttons **D**, **E** and **F** can be used in combination.

Rear seat area ventilation*

Using the front seat area ventilation, the passengers in the rear can ventilate the rear seat area with air from outside (not in air recirculation mode).

The rear seat area is ventilated independently of the ventilation in the front seat area, using a blower fitted in the rear right side trim.

When in use, the fresh air drawn in is cleaned by a dust and pollen filter* and guided into the rear seat area by vents in the roof.

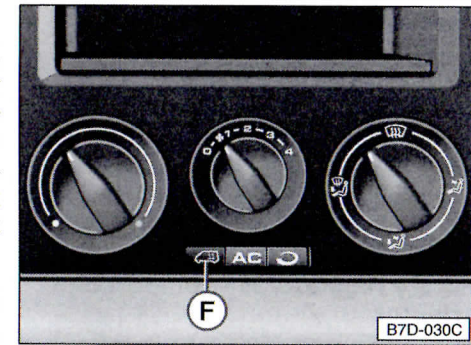

At least one vent in the roof must be open when the blower is functioning as the blower will otherwise switch off due to overheating.

To ensure that the rear seat area ventilation can work properly, the air inlet in front of the windscreen should be kept free of ice, snow and leaves.

Switching on

Press switch over button **F** and turn the rotary switch **G** to blower stages 1 to 3.

Switching off

Press switch over button **F** again or turn the rotary switch **G** to blower stage 0.

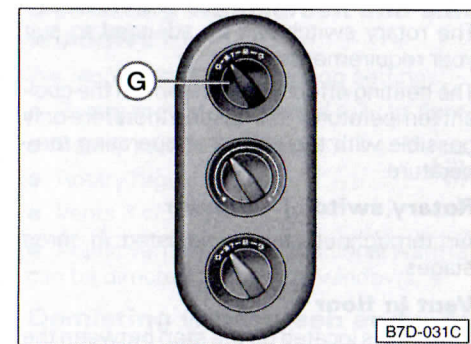

Rotary switch G - Blower

Air throughput can be adjusted in three stages.

Roof outlets

The roof outlets can be closed or opened separately. They can also be adjusted by repositioning the outlet grille.

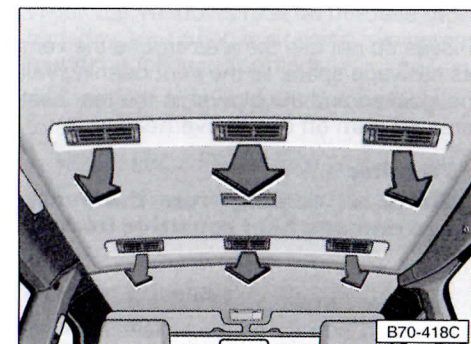

Rear seat area heating*

The rear seat area is heated independently of the standard vehicle heating in the front seat area. The air in the rear seat area is heated via the air recirculation mode.

The rear seat area will only function when switch over button **F** is pressed and when the the blower switch **I** is set to blower stages 1 to 3.

Rotary regulator H – Temperature selector

Clockwise – increases heat output
Anti-clockwise – decreases heat output

The rotary switch can be adjusted to suit your requirements.

The heating effect is dependent on the coolant temperature – full heating therefore only possible with the engine at operating temperature.

Rotary switch I – Blower

Air throughput can be adjusted in three stages.

Vent in floor

The vent is located on the step between the front and rear seat areas behind the right front seat.

Please do not use the area around the vent as stowage space as the vent opening will be blocked and the blower in the rear seat area will turn off due to overheating.

Warning

Warm air coming from the vent can damage heat sensitive items.

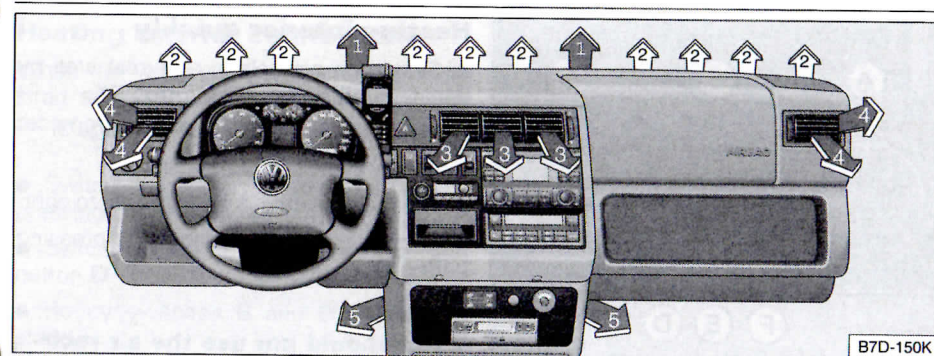
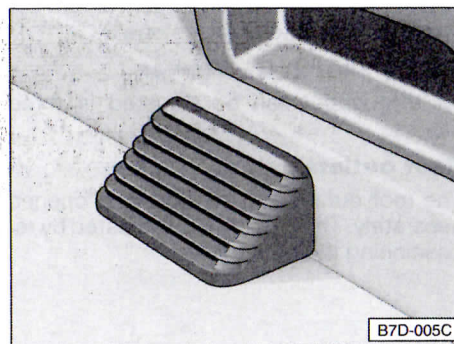
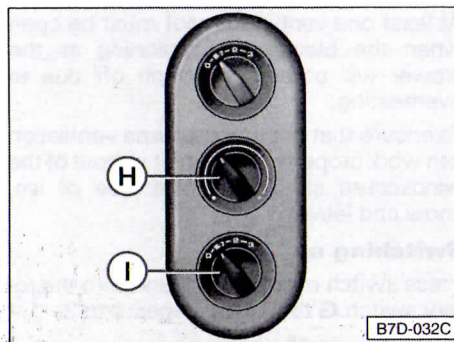
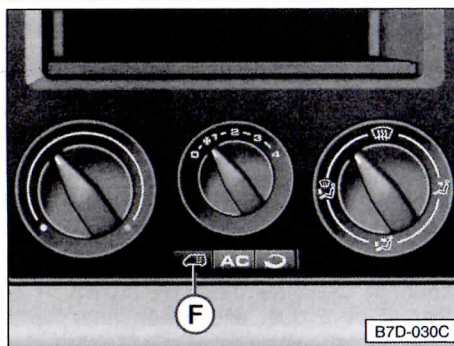

Air vents (front)

Depending on the position of rotary regulator **A** and button **E**, heated or unheated fresh air/cold air flows from all vents which are open.

The outlets are controlled by the rotary regulator **C**.

The vents 3 and 4 can be opened and closed separately:

- vent opened side knurled wheel to **O**
- vent closed side knurled wheel to **●**

By swinging the complete outlet grille of vents 3 and 4 the air flow can be moved vertically.

When the knurled disc in the grille is rotated to and fro the air flow direction is altered laterally.

The lower area of the windscreen can be kept demisted via the vents 2.

Defrosting windscreen and side windows

We recommend the following settings:

- Rotary regulator **A** turned fully to right.
- Rotary switch **B** to stage 3.
- Rotary regulator **C** to
- Vents 3 closed
- Adjust vents 4 so that additional warm air can be directed to the side windows.

Demisting windscreen and side windows

When the windows mist up due to high air humidity, e.g. when it is raining, we recommend the following settings:

- Switch on air conditioner by pressing button **E**
- Rotary switch **B** to stage 2 or 3.
- Rotary regulator **A** at the desired heat output.
- Rotary regulator **C** to
- Vents 3 closed.
- Additional warm air can be directed to the side windows via vents 4.

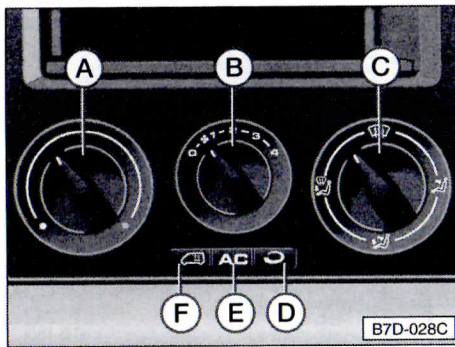

Ventilation (fresh air operation)

With the following settings, unheated fresh air flows from vents 3 and 4 and in roof:

- Turn air conditioner off by pressing button **E**.
 - Switch off air recirculation by pressing button **D**.
 - Switch on controls in rear seat area by pressing the switch over button **F***.
 - Rotary switches **B** and **G*** to desired stage.
 - Rotary switch **I*** to stage 0.
 - Rotary regulator **A** anti-clockwise to the stop
 - Rotary regulator **C** to
 - If windscreen is misted over, rotary regulator **C** to
- If required, regulator **C** can be turned to another position.
- Vents 3 and 4 in roof open.

Heating interior quickly

- Switch on controls in rear seat area by pressing the switch over button **F***.
- Rotary switches **B** and **I*** to stage 3.
- Rotary switch **G*** to stage 3.
- Rotary regulators **A** and **H*** fully to right.
- Switch on air recirculation by pressing button **D**.

Warning

You should not use the air recirculation mode for an extended period of time as no fresh air is drawn in from outside.

Note information on recirculating air operation on page 17.

- Rotary regulator **C** to
- If windscreen is misted over, rotary regulator **C** to
- Vents 3 closed.
- Vents 4 and in roof set as required.

Heating interior comfortably

When the windows are clear and the desired temperature has been reached we recommend the following settings:

- Switch on controls in rear seat area by pressing the switch over button **F***.
- Switch off air recirculation by pressing button **D**.
- Rotary switches **B** and **I*** to desired stage.
- Rotary regulators **A** and **H*** at the desired heat output.
- Set rotary regulator **C** to required air distribution setting
- If windscreen is misted over, rotary regulator **C** to
- Vents 3 and 4 and in roof set as required.

Normal cooling

- Switch off controls in rear seat area by pressing the switch over button **F***.
- Switch on air conditioner by pressing button **E**
- Rotary switch **B** to desired stage.
- Rotary regulator **A** to the desired air temperature (heating is also possible).
- Rotary regulator **C** to desired position.

When rotary regulator **C** is in this position, at least one vent in the dash panel must be open, as the cooling system will otherwise ice up.

- Vents 3 and 4 set as required.

Maximum cooling

- All windows and sliding/tilting roof* closed.
 - Switch on air conditioner by pressing button **E**
 - Rotary switch **B** and **G*** to desired stage.
 - Rotary switch **I*** to stage 0.
 - Rotary regulator **A** anti-clockwise to the stop
 - Rotary regulator **C** to
 - If windscreen is misted over, rotary regulator **C** to
- If the rotary regulator **C** is in this position **no** air recirculation is possible.

- Vents 3 and 4 in roof open.

At least one vent in the roof and in the instrument panel must always be open otherwise the A/C system will ice up.

- Switch on air recirculation by pressing button **D**.

Warning

You should not use the air recirculation mode for an extended period of time as no fresh air is drawn in from outside.

Note information on recirculating air operation on page 17.

Using air conditioner economically

In cooling operation the air conditioner compressor places demands on the engine and therefore influences the fuel consumption. To keep the period switched on as short as possible, the following points should be noted:

- If the inside temperature is very high after the car has been parked in the sun, it is recommended to open doors or windows briefly to enable the hot air to escape.
- The air conditioner should not be switched on during a journey if the windows or sliding/tilting roof* are open.
- If the desired interior temperature can be attained without switching on the air conditioner, the fresh air operation should be selected.

General notes

- When the ambient temperature is high and the air very humid, condensed water can drip off the evaporator and form a puddle under the vehicle. This is quite normal and does not indicate a leak.
- If the air conditioner has not been used for some time, a build-up of natural deposits in the vaporiser can cause odours. To prevent the odours, turn on the air conditioner at full blast at least once a month when the temperature is above 5° C. Open a window for a short period whilst doing this.

- To ensure that the heating, ventilation and air conditioner* can work properly, the air inlet in front of the windscreen should be kept free of ice, snow and leaves.

- The stale air escapes through openings in the luggage compartment side panels. Therefore when loading the luggage compartment ensure that the openings are not covered.

Operating faults

- If the cooling output drops off, switch the A/C off and have the system checked.
 - Should the air conditioner not work at any time, either:
 - the ambient temperature is below about +5°C,
 - the fuse has blown.
- Check fuse and, if necessary, renew it. If the trouble is not due to a defective fuse, switch the system off and have it checked.
- the compressor of the cooling system has switched off temporarily due to the coolant temperature being too high.

Air conditioner* (Commercial models)

The air conditioner is a combined cooling and heating system which provides the maximum possible comfort all the year round.

The cooling system only works when the engine is running, the ambient temperature is above about + 5°C and the blower speed is between 1 and 4 on rotary switch **D**.

When the cooling system is switched on it reduces not only the temperature inside the vehicle but also the air humidity. When the ambient air humidity is high, this not only makes the vehicle occupants feel more comfortable, even in winter, but also prevents the windows from steaming up.

The best possible heating performance and quick defrosting of the windscreen can only be achieved once the engine has reached its normal operating temperature.

Warning

For road safety it is important that all windows are free of ice, snow and mist. Only then can clear vision be guaranteed.

You should, therefore, familiarise yourself with the correct operation of the heating and ventilation system, the removal of dampness and frost from the windows as well as the cooling system.

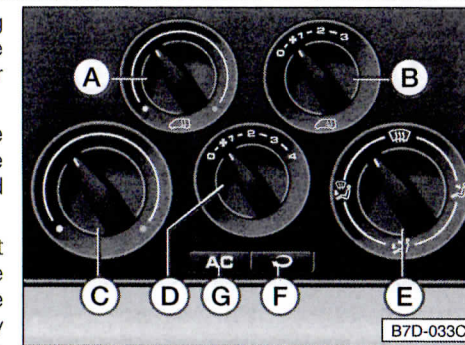

Controls

- A – Rotary regulator – temperature control for additional heater*
- B – Rotary switch – blower for additional heater*
- C – Temperature control rotary regulator
- D – Rotary switch – blower
- E – Rotary regulator – air distribution
- F – Button – air recirculation
- G – Button – air conditioner on/off

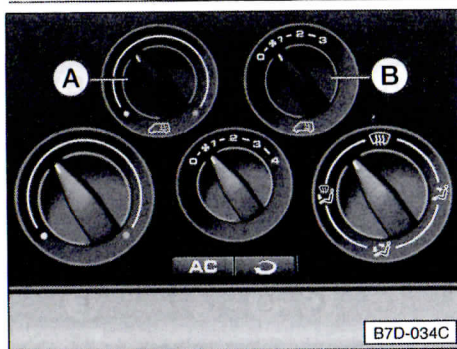

Additional heater*

With the additional heater, the air in the load area can be heated. However, there is no fresh air input as the heat exchanger only works in recirculating operation.

Rotary regulator A – Temperature selector

Clockwise – increases heat output
Anti-clockwise – decreases heat output
The rotary switch can be adjusted to suit your requirements.

The heating effect is dependent on the coolant temperature – full heating therefore only possible with the engine at operating temperature.

Rotary switch B – blower

Air throughput can be adjusted in three stages.

Vent

The vent is located on the step between the front seat and load areas.

Please do not use the area around the vent as stowage space as the vent opening will be blocked and the blower will turn off due to overheating.

Warning

Warm air coming from the vent can damage heat sensitive items.

Air conditioner

● To ensure that the heating, ventilation and air conditioner can work properly, the air inlet in front of the windscreen should be kept free of ice, snow and leaves.

Rotary regulator C – Temperature selector

Clockwise – increases heat output
Anti-clockwise – decreases heat output
When the **air conditioner** is switched on, turning the switch anti-clockwise increases the cooling.

The rotary switch can be adjusted to suit your requirements.

The heating effect is dependent on the coolant temperature – full heating therefore only possible with the engine at operating temperature.





Rotary switch D – Blower

Air throughput can be adjusted in four stages with the blower control. When driving slowly the blower should always be running at a low speed.

On vehicles with a dust and pollen filter* dust, pollen, soot etc. will be held back by the filter regardless of the position of blower switch **D**.

In position 0, the blower and air conditioner are switched off. To prevent contaminated air (smells) entering the vehicle interior, press button **F** (air recirculation).

Rotary reg. E – Air distribution

Regulator to symbol...	Air vent open...	Vents fully open	Vents slightly open
	...at windscreen	1, 2	3, 4
	...at windscreen and in the footwell	1, 2, 5	3, 4
	...to the upper body	3, 4	—
	...in the footwell	5	1, 2, 3, 4

The rotary switch can be adjusted to suit your requirements.

For vent layout, see next page.

Button F – Air recirculation

Air recirculation is selected by pressing this button. A warning lamp lights up in the button.

Air recirculation is switched off by pressing the button again. The warning lamp then goes out.

The air recirculation function prevents strong outside smells entering the vehicle, for example when driving through a tunnel or standing in a traffic jam.

Air recirculation can also be selected if the vehicle is to be heated or cooled quickly. In this mode, air is drawn in from the vehicle interior and heated or cooled.

For reasons of safety, air recirculation is **not** possible if rotary regulator **E** is turned to the following position: .. 

Warning

You should not use the air recirculation mode for an extended period of time, as no fresh air is drawn in and the windows could mist up.

Smoking should be avoided when air recirculation is selected, as the smoke drawn in from the vehicle interior deposits on the evaporator of the air conditioner. This leads to permanent odours when the air conditioner is in operation. These can only be eliminated by exchanging the evaporator, which is time-consuming and expensive.

Button G – Air conditioner on/off

The system is switched on by pressing this button. A warning lamp lights up in the button pressed.

The system is switched off by pressing the button again. The warning lamp then goes out.

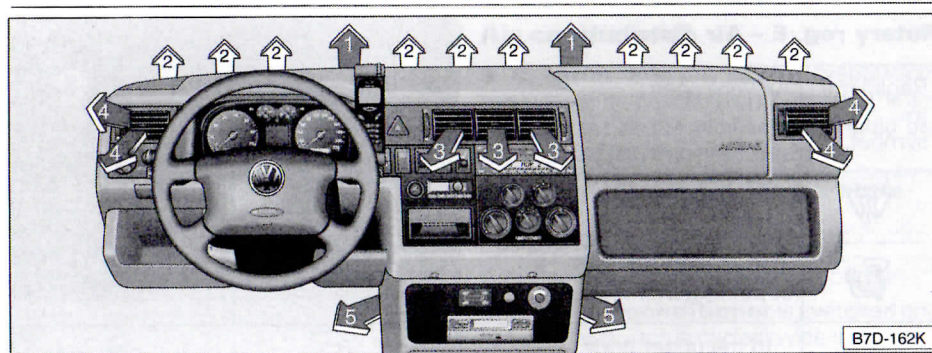

Air vents

Depending on the position of rotary regulator **C** and button **G** heated or unheated fresh air/cold air flows from all vents which are open.

Only unheated fresh air will flow from vents 3.

The vents are controlled by the rotary regulator **E**.

The vents 3 and 4 can be opened and closed separately:

- vent opened side knurled wheel to **O**
- vent closed side knurled wheel to **●**

By swinging the complete outlet grille of vents 3 and 4 the air flow can be moved vertically.

When the knurled disc in the grille is rotated to and fro the air flow direction is altered laterally.

The lower area of the windscreen can be kept demisted via the vents 2.

Defrosting windscreen and side windows

We recommend the following settings:

- Rotary switch **D** to stage 3.
- Rotary regulator **C** turned fully to right.
- Rotary regulator **E** to 
- Vents 3 closed
- Adjust vents 4 so that additional warm air can be directed to the side windows.



Demisting windscreen and side windows

When the windows mist up due to high air humidity, e.g. when it is raining, we recommend the following settings:

- Switch on air conditioner by pressing button **G**
- Rotary switch **D** to stage 2 or 3.
- Rotary regulator **C**, if necessary, into heating range.
- Rotary regulator **E** to 
- Vents 3 closed.
- Additional warm air can be directed to the side windows via vents 4.

Ventilation (fresh air operation)

With the following settings, unheated fresh air flows from vents 3 and 4:

- Rotary switch **B*** to stage 0.
 - Rotary switch **D** to desired stage.
 - Rotary regulators **A*** and **C** anti-clockwise to the stop
 - Rotary regulator **E** to 
 - When windscreen misted up set rotary regulator **E** to 
- If required, regulator **E** can be turned to another position.

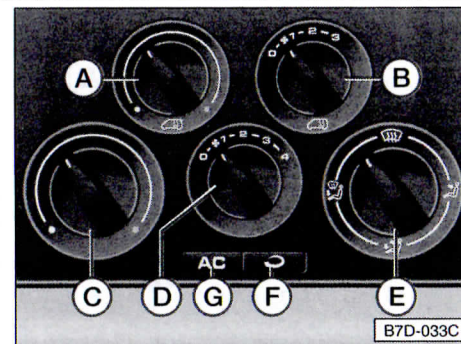



Heating interior quickly

- Rotary switches **B*** and **D** to stage 3.
- Rotary regulators **A*** and **C** fully to right.
- Switch on air recirculation by pressing button **F**.

Warning

You should not use the air recirculation mode for an extended period, as no fresh air is drawn in and the windows could mist up if the air conditioning is off.

Note information on recirculating air operation on page 27.

- Rotary regulator **E** to 
 - When windscreen misted up set rotary regulator **E** to 
- If the rotary regulator **E** is in this position **no** air recirculation is possible.
- Vents 3 closed.
 - Vents 4 set as required.

Heating interior comfortably

When the windows are clear and the desired temperature has been reached we recommend the following settings:

- Switch off air recirculation by pressing button **F**.
- Rotary switches **B*** and **D** to desired stage.
- Rotary regulators **A*** and **C** at the desired heat output.
- Adjust rotary regulator **E** to suit required air distribution
- When windscreen misted up set rotary regulator **E** to 
- Vents 3 closed.
- Set vents 4 as required.

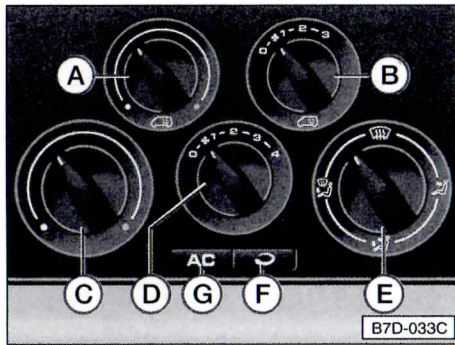



Normal cooling

- Switch on air conditioner by pressing button **G**
- Switch off air recirculation by pressing button **F**.
- Rotary switch **B*** to stage 0.
- Rotary switch **D** to desired stage.
- Rotary regulator **C** to the desired air temperature (heating is also possible).
- Rotary regulator **E** to desired position.

When rotary regulator **E** is in this position , at least one vent in the dash panel must be open, as the cooling system will otherwise ice up.

- Vents 3 and 4 set as required.

Maximum cooling

- All windows and sliding/tilting roof* closed.
- Switch on air conditioner by pressing button **G**
- Rotary switch **D** to highest stage.
- Rotary switch **B*** to stage 0.
- Rotary regulator **A** anti-clockwise to the stop
- Rotary regulator **E** to 
- When windscreen misted up set rotary regulator **E** to 

If the rotary regulator **E** is in this position **no** air recirculation is possible.

- Vents 3 and 4 open.

At least one vent in the instrument panel must always be open otherwise the A/C system will ice up.

- Switch on air recirculation by pressing button **F**.

Warning

You should not use the air recirculation mode for an extended period, as no fresh air is drawn in and the windows could mist up if the air conditioning is off.

Note information on recirculating air operation on page 27.

Using air conditioner economically

In cooling operation the air conditioner compressor places demands on the engine and therefore influences the fuel consumption. To keep the period switched on as short as possible, the following points should be noted:

- If the inside temperature is very high after the car has been parked in the sun, it is recommended to open doors or windows briefly to enable the hot air to escape.
- The air conditioner should not be switched on during a journey if the windows or sliding/tilting roof* are open.
- If the desired interior temperature can be attained without switching on the air conditioner, the fresh air operation should be selected.

General notes

- When the ambient temperature is high and the air very humid, condensed water can drip off the evaporator and form a puddle under the vehicle. This is quite normal and does not indicate a leak.
- If the air conditioner has not been used for some time, a build-up of natural deposits in the vaporiser can cause odours. To prevent the odours, turn on the air conditioner at full blast at least once a month when the temperature is above 5° C. Open a window for a short period whilst doing this.

- The stale air escapes through ventilation slots in the load area side panel trim. These slots should not, therefore, be covered. On vehicles with a full-width partition and on the Pick-up and Double Cab models the stale air escapes through slots in the driver's and passenger doors.

Operating faults

- If the cooling output drops off, switch the A/C off and have the system checked.
- Should the air conditioner not work at any time, either:
 - the ambient temperature is below about +5°C,
 - the fuse has blown.
 Check fuse and, if necessary, renew it. If the trouble is not due to a defective fuse, switch the system off and have it checked.
- the compressor of the cooling system has switched off temporarily due to the coolant temperature being too high.

Climatronic* with separate controls for rear seat area

The Climatronic maintains the selected vehicle interior temperature fully automatically.

To do this temperature of the air flow as well as the blower speed (air volume) and air distribution are altered automatically.

The system also takes account of intense sunlight. This eliminates the need for a manual re-adjustment of the temperature.

We recommend the following standard setting for all times of the year:

Set the temperature to 22 °C (72 °F) and press the AUTO button.

With this setting a pleasant climate in the vehicle is reached most quickly.

This setting should therefore only be altered when required for personal comfort.

The temperature for the rear seat and front seat areas can be set independently of each other using this equipment. The maximum difference in temperature can, however, only be 3°C.

Furthermore, the passengers in the rear have the possibility to adjust the settings for the rear seat area to suit their requirements. This can be done via the controls in the rear seat area.

The best possible heating performance and quick defrosting of the windscreen can only be achieved once the engine has reached its normal operating temperature.

To ensure that the Climatronic can work properly, the air inlet in front of the windscreen should be kept free of ice, snow and leaves.

Warning

For road safety it is important that all windows are free of ice, snow and mist. Only then can clear vision be guaranteed.

You should, therefore, familiarise yourself with the correct operation of the heating and ventilation system, the removal of dampness and frost from the windows as well as the cooling system.

We recommend that you do not smoke in the vehicle when the cooling system is switched on as the Climatronic always functions in air recirculation mode in the rear seat area. Thus the smoke taken in from the vehicle interior will settle on the evaporator. This will lead to permanent odour when the Climatronic is in operation which can only be removed with great effort and at high expense by replacing the evaporator.

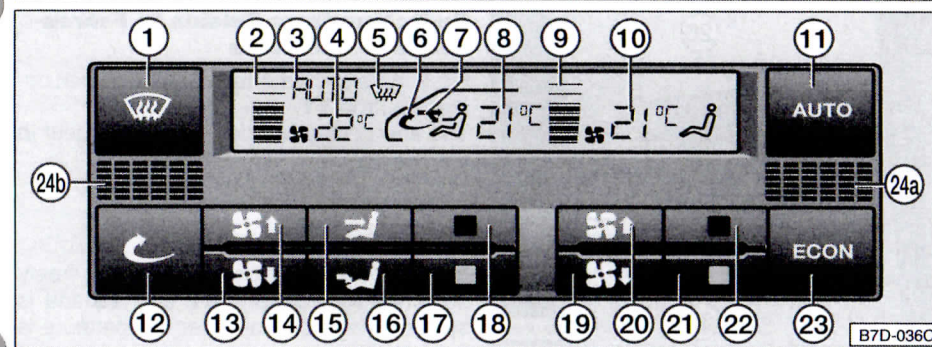

Controls / displays

● Controls instrument panel

Buttons

1 - Button for defrosting windscreen

Display

- 2 - Display for blower speed **front**
- 3 - Display:
AUTO (automatic mode) or
ECON (compressor off) or
OFF (entire system off)
- 4 - Display for ambient temperature
- 5 - Display for defrosting windscreen
- 6 - Display for air recirculation
- 7 - Display for air flow direction
- 8 - Display for selected temperature **front**
- 9 - Blower speed indicator **rear**
- 10 - Display for selected temperature **rear**

Buttons

- 11 - Button for "AUTO"
Automatic operation.
- 12 - Button for air recirculation
- 13 - Button for "Blower slower" for **front**
and button for complete system
"OFF"
- 14 - Button for "Blower faster" **front**
- 15 - Button for "Air flow to upper part of
body"
- 16 - Button for "Air flow to footwell"
- 17 - Button for "Colder" **front**
- 18 - Button for "Warmer" **front**
- 19 - Button for "Blower slower" **rear** and
button for rear system "OFF"
- 20 - Button for "Blower faster" **rear**
- 21 - Button for "Colder" **rear**
- 22 - Button for "Warmer" **rear**
- 23 - "ECON" button (system off)
- 24 - Interior temperature sensor
a - left hand drive vehicles
b - right hand drive vehicles

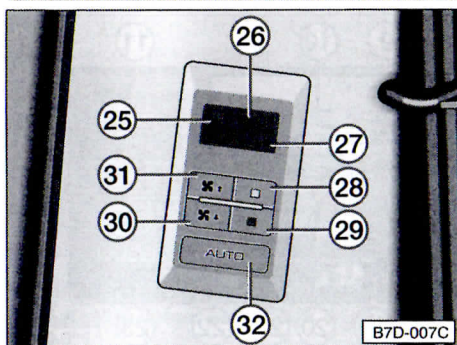

● **Controls in rear seat area**

Display

- 25 - Blower speed indicator **rear**
- 26 - Display for selected temperature **rear**
- 27 - Display AUTO (automatic mode) or OFF (entire system off)

Buttons

- 28 - Button for "Warmer" **rear**
- 29 - Button for "Colder" **rear**
- 30 - Button for "Blower slower" **rear**
- 31 - Button for "Blower faster" **rear**
- 32 - Button "Auto" for resetting the system to front seat area setting

Using the system

When ignition has been switched on the system normally works in the automatic mode. Displays **2, 3, 4, 8, 9** and **10** appear.

If the settings deviated from automatic operation before the ignition is switched off the selected functions are permanently stored. The function "Air recirculation" is cancelled 20 minutes and the function "Air conditioner off" one hour after the ignition has been switched off.

Switching from Celsius to Fahrenheit and vice versa

First press and hold button **23** and then operate button **11**.

The appropriate temperature will appear in the display.

Notes on Automatic mode (AUTO)

● The interior temperature can be freely selected with buttons **17** and **18** and is stored always until another temperature is selected.

The interior temperature can be set between +18°C (64°F) and +29°C (86°F). These are approximate figures which can be either slightly higher or lower depending on the ambient conditions and the control field selected.

If temperatures below +18°C (64°F) are selected "LO" appears in the display. With temperatures above +29°C (86°F) "HI" is displayed.

In the positions "LO" and "HI" the system works continuously at maximum cooling or heating output. The temperature is not regulated.

● If the blower speed is changed up or down a stage, automatic mode is still retained.

● In certain operating conditions it may be found that the system temporarily carries out functions which are not quite as expected. This includes, for example, that for a few seconds after starting from cold, air is directed mainly into the footwell. This is intentional so that damp air in the system does not cause the windows to mist up.

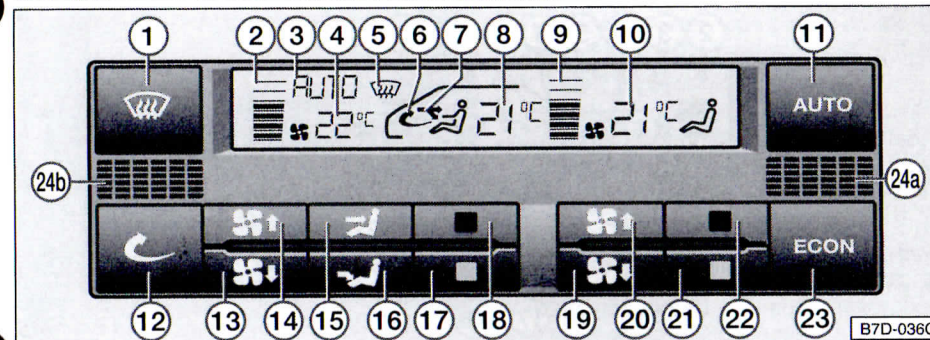

Deviation from Automatic mode

In nearly all cases the Automatic mode offers the best conditions for the comfort of the vehicle occupants all the year round.

In isolated cases however it can be necessary to move away from certain functions of the automatic mode by pressing various buttons. The Climatronic still works automatically:

● With buttons **13** and **14** the blower speed and thus the air volume can be increased or reduced. This is shown by an increase or decrease in the number of lines in position **2**.

- By pressing button **1**
 - the ECON operation is switched off
 - the air recirculation mode is switched off
 - the windscreen and side windows can be defrosted or kept free of misting (direct vents **4** onto side windows)

- the dehumidifying and defrosting effect for the windscreen can be increased if, for example persons with damp clothing are picked up shortly after moving off.

● **Air recirculation** is selected by pressing button **12**. The symbol **6** appears in the display.

The air recirculation function prevents strong outside smells entering the vehicle, for example when driving through a tunnel or standing in a traffic jam.

Air recirculation can also be selected if the vehicle is to be heated or cooled quickly. In this mode, air is drawn in from the vehicle interior and heated or cooled.

Warning
You should not use the air recirculation mode for an extended period of time, as no fresh air is drawn in and the windows could mist up when the cooling system is switched off.

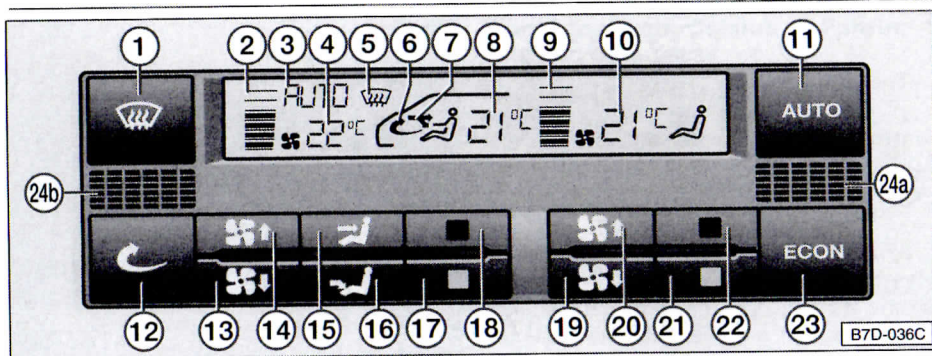

Smoking should be avoided when air recirculation is selected, as the smoke drawn in from the vehicle interior deposits on the evaporator of the Climatronic. This leads to permanent odours when the Climatronic is in operation. These can only be eliminated by exchanging the evaporator, which is time-consuming and expensive.

- With buttons **15** and **16** the air flow can be directed to the upper part of the body or into the footwell.

The air distribution buttons **1**, **15** and **16** can be used in combination.

- Button **23** (ECON) **switches the cooling system off**. In this mode, the heating is automatically regulated (without air dehumidifying and cooling), with the desired interior temperature being attained as quickly as possible and maintained.

Please note that in ECON made, the desired interior temperature cannot be lower than the ambient temperature.

- The interior temperature can be set using buttons **17** and **18**.

The combination ECON mode with air recirculation is only possible if, in ECON mode, first button **12** is pressed and then the ECON button.

Pressing buttons **1**, **11** or **12** will switch off the ECON mode.

- The entire system can switched off with button **13**. Press and hold the button **13** until the word "OFF" appears in display **3**. This function should only be used in isolated cases, e.g. if there is a fault in the system.

Warning

Fresh air from outside will not be fed in when the system is switched off. You must open the windows if you are driving with the system switched off to ensure that enough fresh air enters the vehicle.

Note

When the special functions are no longer required the automatic mode should be switched on again as soon as possible by pressing the button **11** (AUTO).

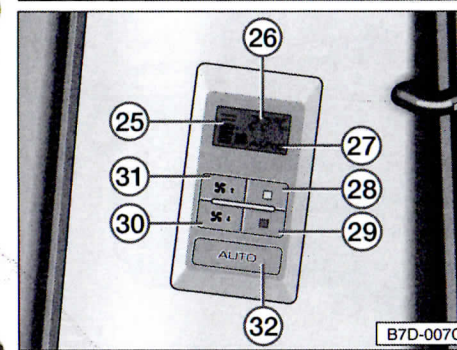

- The entire system can switched off with buttons **19** or **30**. Press and hold until the word "OFF" appears in display **27**.

- Cooled air via the vents in the roof or warmed air through the vents in the floor to the rear can be controlled depending on the setting for the front (buttons **13 - 20** or buttons **13 - 20**).

- The interior temperature can be freely selected with buttons **21**, **22** or **28**, **29** and remains stored until another temperature is selected. Please note:

A difference of up to 3°C is possible between the temperature settings for the front seat area (pos. **8**) and the rear seat area (pos. **10**).

If the Climatronic determines that the interior of the vehicle must be **warmed up** it will also activate the additional heat exchanger. The warm air flows out through the vents in the floor.

If the Climatronic determines that the interior of the vehicle must be **cooled down**, cooled air is introduced through the open air vents in the roof.

Climatronic for the rear seat area

The Climatronic in the rear only functions in the air recirculation mode. Fresh air is not fed into the vehicle.

Smoking should be avoided when air recirculation is selected, as the smoke drawn in from the vehicle interior deposits on the evaporator of the Climatronic. This leads to permanent odours when the Climatronic is in operation. These can only be eliminated by exchanging the evaporator, which is time-consuming and expensive.

- With buttons **19** and **20** as well as buttons **30** and **31** the blower speed and thus the air volume can be increased or reduced. This is shown by an in/decrease in the number of lines in positions **9** and **25**.

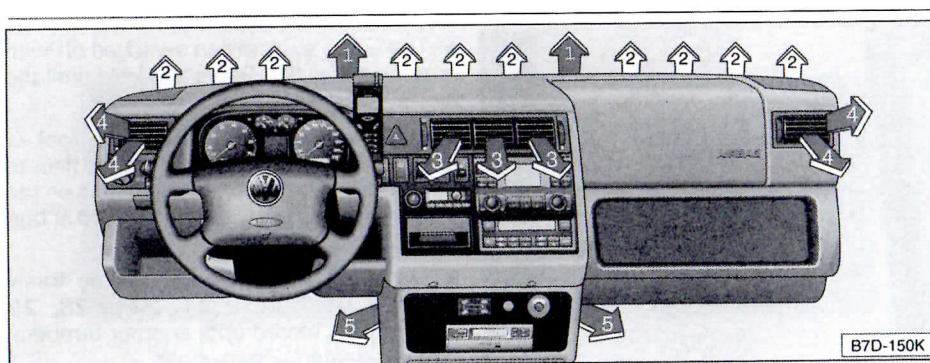

Air vents in driver's compartment (front)

When the appropriate buttons are pressed, heated, unheated air or cooled air flows from all vents in the front.

The vents are controlled automatically by the Climatronic in AUTO mode.

The outlets are controlled by the buttons **1, 15, 16**.

The vents 3 and 4 can be opened and closed separately:

- vent opened
side knurled wheel to ○
- vent closed
side knurled wheel to ●

By swinging the complete outlet grille of vents 3 and 4 the air flow can be moved vertically.

During automatic operation, one of the vents 3 or 4 must be opened as the cooling system could otherwise ice up.

When the knurled disc in the grille is rotated to and fro the air flow direction is altered laterally.

The lower area of the windscreen can be kept demisted via the vents 2.

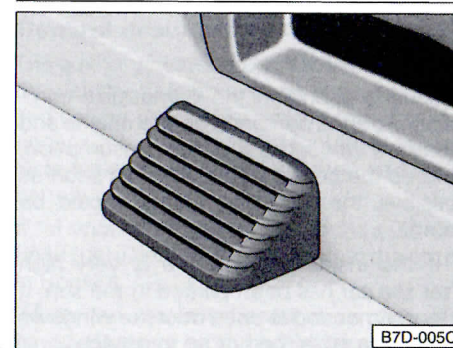

Air vents in rear seat area

Vent in floor

The vent for the additional heater is located on the step between the front seat and rear seat areas.

Please do not use the area around the vents as storage space as the vent openings will be blocked and the additional heat exchanger blower will turn off due to overheating.

Warning
Warm air coming from the vent can damage heat sensitive items.

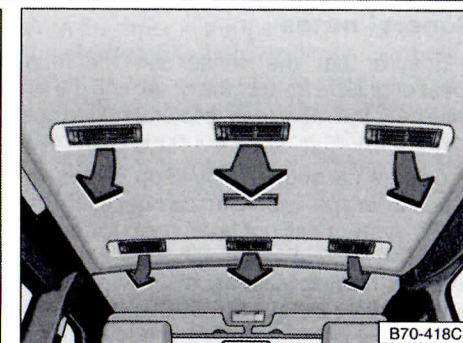

Vent in roof

The temperature and air flow from the vents in the roof can be set independently of the setting for the front seat area cab using buttons **21 - 24** or **28 - 31**.

Please note that only cold air – no warm air – comes through the vents in the roof.

The roof outlets can be closed or opened separately and can also be adjusted by pivoting the outlet grilles.

● When cooled air mode is switched on, at least one vent in the roof area must be open or the cooling system may ice up.

General notes

- Ensure that the sensor on the loud speaker grille in front of the driver and the air grille near the radio (pos. 24a or 24b) are not covered up.
- Odours caused by a build-up of natural deposits in the vaporiser can occur if the AUTO system has not been used for some time. The cooling system should be turned on at full blast at least once a month when temperatures are above +5°C to clear or to prevent the odours. Open a window briefly when doing this.
- The stale air escapes through openings in the luggage compartment side panels. Therefore when loading the luggage compartment ensure that the openings are not covered.
- When the ambient temperature is high and the air very humid, condensed water can drip off the evaporator and form a puddle under the vehicle. This is quite normal and does not indicate a leak.
- To prevent the windows from misting up the blower should be running slowly when driving at low speeds. To do this select ECON or AUTO.

Using Climatronic economically

In cooling operation the Climatronic compressor places demands on the engine and therefore influences the fuel consumption. To keep the period switched on as short as possible, the following points should be noted:

- If the inside temperature is very high after the car has been parked in the sun, it is recommended to open doors or windows briefly to enable the hot air to escape.
- The compressor should not be switched on during a journey if the windows or sliding roof* are open.
- ECON mode should be selected if the desired interior temperature can be attained without switching on the air conditioner.

Operating faults

- If, after switching on the ignition, all symbols in the display area flash for about 15 seconds, there is a fault in the system – contact a Volkswagen dealer.
- If the cooling output drops off, switch the A/C off and have the system checked.
- Should the cooling system not work at any time, either:
 - the ambient temperature is below about +5°C,
 - the Climatronic compressor has switched off due to coolant temperature being too high.
 - or the fuses have blown.

Check fuse and, if necessary, renew it. If the trouble is not due to a defective fuse, switch the system off and have it checked.

Auxiliary heater*

General description

The auxiliary heater works independently of the vehicle heating and ventilation system and can be used when on the move or stationary. It is supplied with fuel from the vehicle tank and electricity from an additional battery.

If, at winter temperatures, you should use RME fuel (Diester), please refer to the notes in Booklet 3.2, "Diesel".

When the auxiliary heater is running, exhaust gases are produced which are guided out through an exhaust pipe fitted in the area of the front left mud guard.

Smoke could develop if the percentage share of RME in the mix is higher than 50 %, during short journeys or at low ambient temperatures.

With the timer in the instrument panel up to three different switch-on times can be selected. It is thus possible to start the heater without actually being in the vehicle.

The heating period as programmed in the factory is 120 minutes. You can alter this setting either permanently or for one single occasion.

If you disconnect the additional battery or remove the fuse for the auxiliary heater or the fuse has to be replaced, all switch on times will be deleted. After the battery has been reconnected, the symbols and signs will flash on and off in the display. Press button **3** once and set the current time, the preset day and the actual day of the week so that the heating can start at the right times.

On vehicles with a solid partition, only the load area is heated.

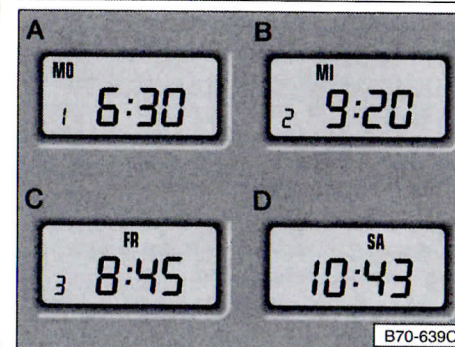
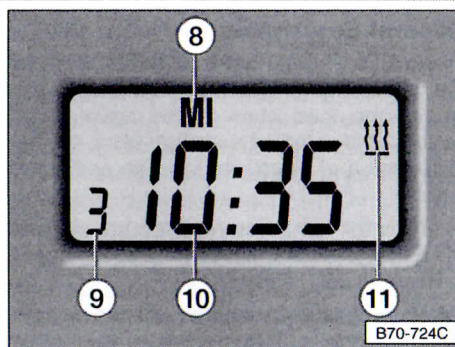
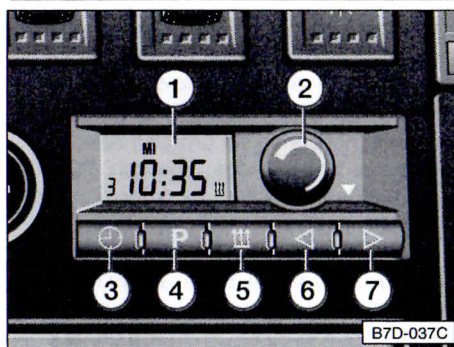

Controls

- 1 - Display
- 2 - Rotary regulator for heating
- 3 - Button for current time and day of week
- 4 - Button for setting time and day and for activating and deactivating the heater
- 5 - Push button for "On" or "Off"
- 6 - Button for resetting time or preset time back, shortening heating time
- 7 - Button for setting time or preset time forward, lengthening heating time and setting switch-on day.

Warning

- **The auxiliary heater must be switched off when filling up.**
- **There is a danger of poisoning when running the auxiliary heater in confined spaces !**

Display

- 8 - Display for set day and switch-on day
- 9 - Display for activation of the heating
- 10 - Display for
 - Time
 - Heating period
 - Switch-on time
 - Fault in auxiliary heater system
- 11 - Display for:
 - heating on (Symbol can be seen)
 - heating off (Symbol cannot be seen)

Setting the actual time

- Press and hold button **3** until the time stops flashing.
 - Set correct time with buttons **6** or **7**.
 - Release buttons after time has been set.
- The inputs are stored in the memory if no further input is made within about 10 seconds.

Setting the current day of the week

- Press and hold button **3** until the time stops flashing.
- Then wait until the day of the week display flashes.
- Set correct day of week with buttons **6** or **7**.
- Release buttons after time has been set.

The inputs are stored in the memory if no further input is made within about 10 seconds.

Setting preset day and switch-on time

Three switch on times can be set. Only one switch on time can, however, be activated.

Before starting

Call up one of the three switch-on times by pressing button **4**. The following displays will appear in turn:

- Field A – **1**. Switch-on time
- Field B – **2**. Switch-on time
- Field C – **3**. Switch-on time
- Field D – The current time and day

At the same time the preset day of week is displayed alongside the preset switch-on time each time the button is pressed.

Setting switch-on time

For the initial input and for each change to an old input, first call up one of the switch-on times listed under A – C by pressing button **4**.

Press button **6** or **7** once. Wait until the switch on time starts to flash on and off. Set the desired switch-on time using buttons **6** or **7**.

The preset time remains stored and can be called up again with button **4** so that the heater switches on again at that time.

Setting preset day

For the initial input and for each change to an old input, first call up one of the switch-on times listed under A – C by pressing button **4**.

Press button **6** or **7** once. Wait until the preset day starts to flash on and off. Then set the desired preset day using buttons **6** or **7**.

After setting

The inputs are stored in the memory if no further input is made within about 10 seconds of setting a time and day of the week. However, the numbers **1, 2** or **3** (for the appropriate switch-on time) remain in the display to indicate that the heater is activated.

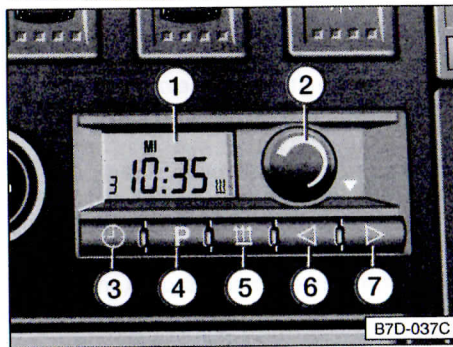

Switching on heater (manually without timer)

● Press button **5**. The symbol **11** appears in the display.
After heater has been switched on it takes a little time before heat can be felt.

Adjusting heat

The heat is infinitely adjustable using the rotary regulator **2**.

When the desired temperature has been reached it is then held fairly constant by the heater thermostatically.

Heater running time

When ignition is switched off

- switched on by timer
- The auxiliary heater runs for **up to 2 hours** when the ignition is switched off after which it switches itself off.
- switched on manually

By pressing button **5** the heating **operates up to 2 hours** when the ignition is switched off. The heating, however, may not be controlled by the timer at the same time. You can shorten the heater running time by pressing button **6** or lengthen it by pressing button **7**.

Lengthening running time permanently (changing pre-set)

Switch off heating by pressing button **5**. Press button **6** until the display starts to blink. Release button **6**. A running time of between 10 and 120 minutes can be set using the buttons **6** or **7**.

Release the buttons after the setting procedure is finished. The altered heater running time has been stored.

Lengthening running time once

With the auxiliary heater switched on, the running time can be set between 1 and 120 minutes using buttons **6** or **7**.

Release the buttons after the setting procedure is finished.

Permanent operation of the auxiliary heater

Permanent operation is only possible if the auxiliary heater is not being controlled by the timer.

When ignition is switched on

Switch on the heating by pressing button **5**.

When ignition is switched off

Switch on the heating by pressing button **5**. Set the heating period to 120 minutes using button **7**. Then press button **7** again. ON appears in the display. This confirms that the heating is in permanent operation.

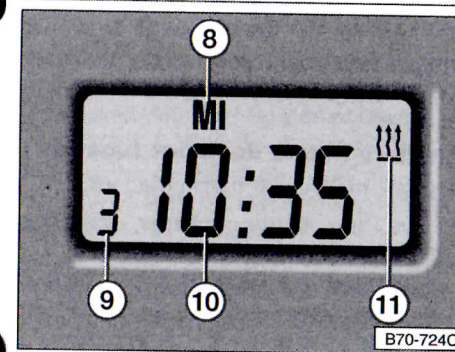

Switching on heater (automatically using timer)

Three switch on times can be set. Only one switch on time can, however, be activated.

Activating the heater

After setting the required switch-on time or pressing button **4**, the figure **1**, **2** or **3** will appear on the left-hand side of the display – see position **9**.

The heater is activated and will start up at the preset time only if the figure remains visible. The activation is confirmed by the flashing symbol in button **5**.

Set the required heater output using rotary regulator **2**.

Deactivating the heater

● If the activation (**not the switch-on time!**) is to be cancelled, press button **4** until the number (pos. **9**) in the display disappears.

Daily programming

An example:

The heater was activated for Monday at 6.30 am. After this programmed time has passed, it can be reset for the following day (Tuesday) at the same time (6.30 am).

To do this press button **4** once. The heating is activated for the next day. The corresponding preset day and switch-on time are shown briefly in the display.

Switching heater off

Warning

- **The heater must be switched off when filling the tank. You do not, however, need to wait until the heater has stopped running before filling up (see notes).**
- **There is a danger of poisoning when running the auxiliary heater in confined spaces !**

The heater can be switched off by pressing button **5**. Symbol **11** disappears. The auxiliary heater blower will, however, continue to function for some time afterwards.

If the ignition is switched off when the auxiliary heater is on, the heater will continue for approximately 15 minutes before switching off.

Notes

- Every time the heater is switched off the blower continues to run for a while to cool the heater down quicker. When filling tank it is not necessary to wait to end of run-on.
- When driving cross-country or through mud or deep snow the heater exhaust pipe can become blocked. The pipe is located near the front left mudwing. Before switching the heater on in these conditions, check that the pipe is clear.
- The switch-on time can be programmed up to one week in advance.
- The following official regulation is applicable in Germany:

The heater of the heat exchanger can be used for 10 years. **After this period the heater must be replaced by a Genuine heat exchanger in a Volkswagen Dealership.** To enable this period of time to be monitored the year when the heater is taken into use is marked on the maker's plate on the heater (under vehicle floor).

The Volkswagen dealer enters the date of replacement on the plate on the heater.

Operating faults

If these individual remedies do not meet with success, your Volkswagen dealer will be pleased to help.

Auxiliary heater does not function

- Check the level of fuel in the tank.
- Have the battery charge condition checked.
- Check the fuses, replace if necessary.
- Adjust the switch-on time to the correct time.
- Check if the air vent or air intake opening may be blocked by some object. Remove such objects if present.

Vent

The vent is located behind behind the left seat on the step between the front seat and rear seat areas.

Warning

Warm air coming from the vent can damage heat sensitive items.

Air intake opening

The air intake opening is in the lower left hand side of the side trim behind the left hand seat.

Please do not use the space between the air intake opening and vent for storage. The intake opening could be blocked and switch off auxiliary heater as a result.

Additional water heater*

General description

The additional water heater can be used when on the move or stationary. The heater is supplied with fuel from the vehicle tank and electricity from the vehicle battery.

If, at winter temperatures, you should use RME fuel (Diester), please refer to the notes in Booklet 3.2, "Diesel".

When the engine is switched off, the additional water heater will heat the coolant in the heating circuit and supplies the heat exchanger in the front seat area with warm coolant. The heat is only introduced to the interior via the front heat exchanger. When the engine is running, the heating will also heat the coolant in the engine coolant circuit.

The coolant is warmed by an additional heater when the engine is running. The exhaust gases which are produced as a result are guided out through an exhaust pipe which is fitted in the area of the front left mud guard.

Smoke could develop if the percentage share of RME in the mix is higher than 50 %, during short journeys or at low ambient temperatures.

You can programme the switch-on time using the timer. In this way it is possible to start the heating without actually being in the vehicle yourself.

The vehicle battery can be discharged very quickly if the additional water heater is used for a long period when the vehicle ignition is switched off.

For this reason, the heating period should never be more than 30 minutes when the vehicle ignition is switched off. For the same reason, the additional water heater should never be used several times in quick succession.

If you disconnect the vehicle battery or remove the fuse for the additional water heater or the fuse has to be replaced, all switch on times will be deleted. If this happens, you must reset the actual time, the preset day and the actual day of the week so that the heating can start at the right times. You should monitor the heating period and change it as necessary.

Warning

- **The additional water heater must be switched off when filling the tank.**
- **When running the auxiliary heater in confined spaces there is a danger of poisoning!**

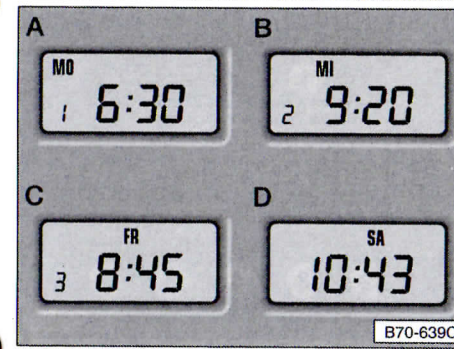
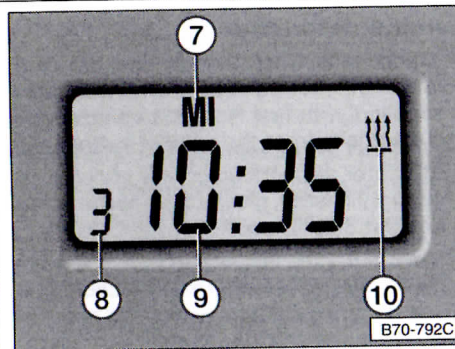
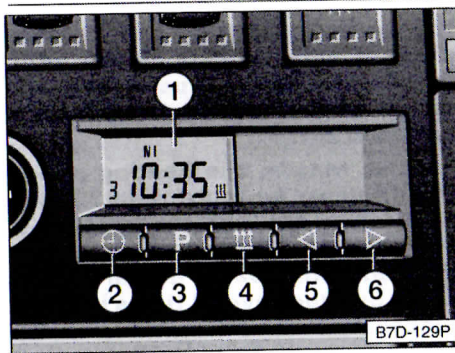

Timer

Controls

- 1 - Display
- 2 - Button for current time and day of week
- 3 - Button for setting time and day and for activating and deactivating the heater
- 4 - Push button for "On" or "Off"
- 5 - Button for resetting time or preset time back, shortening heating time
- 6 - Button for setting time or preset time forward, lengthening heating time and setting switch-on day.

Display

- 7 - Display for set day and switch-on day
- 8 - Display for activation of the heating
- 9 - Display for
 - Time
 - Heating period
 - Switch-on time
 - Fault in auxiliary heater system (Fault code display)
- 10 - Display for:
 - heating on (Symbol can be seen)
 - heating off (Symbol cannot be seen)

Setting the actual time

- Press button **2** until the time starts to flash on and off.
- Set correct time with buttons **5** or **6**.
- Release buttons after time has been set.

The inputs are stored in the memory if no further input is made within about 10 seconds.

Setting the current day of the week

- Press button **2** until the time starts to flash on and off.
 - Then wait until the day of the week display flashes.
 - Set correct day of week with buttons **5** or **6**.
 - Release buttons after time has been set.
- The inputs are stored in the memory if no further input is made within about 10 seconds.

Setting preset day and switch-on time

Three switch on times can be set. Only one switch on time can, however, be activated.

Before starting

Call up one of the three switch-on times by pressing button **3**. The following displays will appear in turn:

- Field A - **1**. Switch-on time
- Field B - **2**. Switch-on time
- Field C - **3**. Switch-on time
- Field D - The current time and day

At the same time the preset day of week is displayed alongside the preset switch-on time each time the button is pressed.

Setting switch-on time

For the initial input and for each change to an old input, first call up one of the switch-on times listed under A - C by pressing button **3**.

Press button **5** or **6** once. Wait until the switch on time starts to flash. Then set the desired switch-on time using buttons **5** or **6**.

The preset time remains stored and can be called up again with button **3** so that the heater switches on again at that time.

Setting preset day

For the initial input and for each change to an old input, first call up one of the switch-on times listed under A - C by pressing button **3**.

Press button **5** or **6** once. Wait until the preset day starts to flash. Then set the desired preset day using buttons **5** or **6**.

After setting

The inputs are stored in the memory if no further input is made within about 10 seconds of setting a time and day of the week. However, the numbers **1, 2** or **3** (for the appropriate switch-on time) remain in the display to indicate that the heater is activated.

Additional water heater running time

The heating period as programmed in the factory is 30 minutes. You can alter this setting either permanently or for one single occasion.

We recommend that you use the factory setting of 30 minutes.

The vehicle battery can be discharged very quickly if the additional water heater is used for a long period when the vehicle ignition is switched off.

Please read the notes on page 47.

When ignition is switched off

– switched on by timer

The auxiliary heater runs for **up to 2 hours** when the ignition is switched off after which it switches itself off.

– switched on manually

By pressing button **4** the heating **operates up to 2 hours** when the ignition is switched off. The heating, however, may not be controlled by the timer at the same time. The running time can either be shortened by pressing button **5** or lengthened by pressing button **6**.

Lengthening running time once

The running time for the additional water heater can be set between 1 and 120 minutes using buttons **5** or **6**.

Release the buttons after the setting procedure is finished.



Lengthening running time permanently (changing pre-set)

Switch off the additional water heater by pressing button **4**. Press button **5** until the running time display flashes. Then release button **5**. The running time can be set between 10 and 120 minutes by pressing buttons **5** or **6**.

Release the buttons after the setting procedure is finished. The altered heater running time has been stored.

Permanent operation of the additional water heater

Permanent operation of the additional water heater is only possible if the heater is not being controlled by the timer.

When ignition is switched on

Switch on the heating by pressing button **4**.

When ignition is switched off

Permanent operation of the additional water heater is **not** possible when the ignition is switched off.

Switching on heater (with ignition off)

● Manual without timer

Press button **4**.

The symbol **10** appears in the display.

After heater has been switched on it takes a little time before heat can be felt.

● Automatically with timer

Three switch on times can be set. Only one switch on time can, however, be activated.

Activating the heater

After setting the required switch-on time or pressing button **3**, the figure 1, 2 or 3 will appear on the left-hand side of the display – see position **8**.

The heater is activated and will start up at the preset time only if the figure remains visible. The activation is confirmed by the flashing symbol in button **4**.

Deactivating the heater

● If the activation (**not the switch-on time!**) is to be cancelled, press button **3** until the number (pos. **8**) in the display disappears.

Notes

- If not activated, the heater will not start at the preset time!
- Once the switch-on time has been confirmed it will only run once. The time can, however, be repeated by reconfirming. By doing this the input remains stored in the memory.
- For vehicles with **heating and ventilation or air conditioner***:
 - The rotary regulator to set the temperature must be turned fully to the right when the additional water heater is switched on.
 - The rotary regulator for air distribution should also be turned fully to the right.
 - The rotary switch for the blowers and air recirculation has no function when the additional water heater is switched on or is working in stationary operation. The front blower functions automatically at level 2.
- For vehicles with **Climatronic***:
 - When the additional water heater is switched on or working in stationary operation, "HE" will appear in the Climatronic display.
 - Temperature, air distribution and the blowers are controlled by the Climatronic.

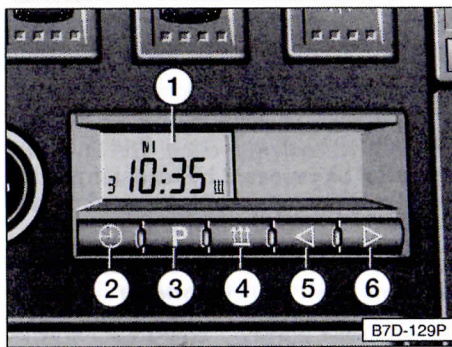

Switching on heater (manually without timer)

Press button **4**.

The symbol **10** appears in the display.

When driving it is only possible to switch the heating on and off **manually** – any programmed switch-on times will be ignored. The length of heating operation is **not** limited when the ignition is switched on.

Notes

- For vehicles with **heating and ventilation or air conditioner***:

- The rotary regulator to set the temperature must be turned fully to the right when the additional water heater is switched on.
- The rotary regulator for air distribution should also be turned fully to the right.

- For vehicles with **Climatronic***:

The Climatronic will continue to function normally when the additional water heater is switched on and in driving operation.

Daily programming

An example:

The heater was activated for Monday at 6.30 am. After this programmed time has passed, it can be reset for the following day (Tuesday) at the same time (6.30 am).

To do this press button **3** once. The heating is activated for the next day. The corresponding preset day and switch-on time are shown briefly in the display.

Switching heater off

Warning

- **The heater must be switched off when filling the tank. You do not, however, need to wait until the heater has stopped running before filling up (see notes on next page).**

- **There is a danger of poisoning when running the auxiliary heater in confined spaces !**

The heater can be switched off by pressing button **4**. Symbol **10** disappears. The auxiliary heater blower will, however, continue to function for some time afterwards.

If the vehicle ignition is switched off while the additional water heater is switched on, the heater will run for approximately 15 minutes before the additional water heater switches off.

Notes

- Every time the additional water heater is switched off the blower will continue to run for a while to cool the heater down more quickly. When filling tank it is not necessary to wait to end of run-on.

- When driving cross-country or through mud or deep snow the heater exhaust pipe can become blocked. The pipe is located near the front left mudwing. Before switching the heater on in these conditions, check that the pipe is clear.

- The switch-on time can be programmed up to one week in advance.

- The following official regulation is applicable in Germany:

The heater of the heat exchanger can be used for 10 years. **After this period the heater must be replaced by a Genuine heat exchanger in a Volkswagen Dealership.** To enable this period of time to be monitored the year when the heater is taken into use is marked on the maker's plate on the heater (under vehicle floor).

The Volkswagen dealer enters the date of replacement on the plate on the heater.

Operating faults

Additional water heater does not function

- Check the level of fuel in the tank.
- Check the fuses, replace if necessary.
- Adjust the switch-on time to the correct time.
- Have the vehicle battery charge condition checked.

If these individual remedies do not meet with success, your Volkswagen dealer will be pleased to help.

ALPHABETICAL INDEX

A

- Additional heat exchanger
 - Climatronic 39
- Additional heater 41, 47
 - Heating and ventilation .. 11, 26
- Additional water heater 47
 - Controls 48
- Air conditioner 15, 25
 - Air recirculation switch 17
 - Controls 15, 25
 - Fresh air operation 22
 - Temperature control 16
- Air recirculation switch
 - Air conditioner 17
 - Climatronic 35
 - Heating and ventilation 4, 12, 27
- Air vents
 - Additional heat exchanger 6, 11, 20, 26, 39
 - Air conditioner 21
 - Climatronic 38
 - Heating and ventilation 7, 13, 28
 - Passenger compartment 39
- Auxiliary heater 41
 - Controls 42
 - Permanent operation 44, 50
 - Running time 44, 50

B

- Blower 3, 16
 - Heating and ventilation 5, 6, 11, 19, 20
 - Rear seat area ventilation 5, 19, 20
- Blowers 32

C

- Climatronic 32
 - Air recirculation switch 35
 - Controls 33
- Controls
 - Additional water heater 48
 - Air conditioner 15, 25
 - Auxiliary heater 42
 - Climatronic 33
 - Heating and Ventilation 2, 10

D

- Defrosting windows ... 8, 13, 28, 33
 - Air conditioner 21
- Diesel engines
 - Additional heater 41, 47

ALPHABETICAL INDEX

H

- Heating 2, 10, 11, 15, 25, 26
- Heating and ventilation
 - Air recirculation switch 4, 12, 27
 - Controls 2, 10
 - Fresh air operation 9, 14, 29
 - Temperature control ... 3, 11, 26

O

- Operating faults .. 24, 31, 40, 46, 53

R

- Rear seat area heating 6
- Rear seat area ventilation .. 5, 19, 20

T

- Temperature control
 - Auxiliary heater 44
 - Climatronic 32
- Temperature selector
 - Heating and ventilation 3, 11, 16, 26
- Timer 41

V

- Ventilation 2, 5, 9, 10, 14, 15, 19, 20, 24, 25, 29, 31, 36, 40
 - Air conditioner 22

W

- Windows
 - Defrosting 8, 13, 21, 28, 33

VOLKSWAGEN AG is working continuously on the development of all types and models. Please appreciate that we must reserve the right to change our models in shape, equipment and technology at any time. No legal commitment is therefore implied by the details, illustrations and descriptions in this manual.

The texts, illustrations and norms in this manual are based on the information available at the time of going to print.

Reprinting, reproducing or translation, in whole or in part, is not permitted without written permission from VOLKSWAGEN AG.

All rights are reserved expressly by VOLKSWAGEN AG. Subject to modification without notice.

Produced in Germany

© VOLKSWAGEN AG

 This paper was manufactured from pulp bleached without using chlorine.

