

Serviceanleitung • Service Manual • Manuel de service • Manual de servicio

(D) Weitere Dokumentationen

Schaltbild 8 622 401 392
 Ersatzteilliste Alpha CC 8 622 401 268
 Ersatzteilliste Alpha Europa 8 622 401 384

(F) Documentation complémentaire

Schéma du poste 8 622 401 392
 Liste de rechanges Alpha CC 8 622 401 268
 Liste de rechanges Alpha Europa 8 622 401 384

(GB) Supplementary documentation:

Circuit diagram 8 622 401 392
 Spare part list Alpha CC 8 622 401 268
 Spare part list Alpha Europa 8 622 401 384

(E) Documentación suplementaria

Esquema 8 622 401 392
 Lista de repuestos Alpha CC 8 622 401 268
 Lista de repuestos Alpha Europa 8 622 401 384

(D) Inhaltsverzeichnis

Belegung des Anschlußkästchens 1
 Darstellung der Abgleichelemente 2
 Darstellung der Meßpunkte 3
 Voreinstellungen / Abgleichhinweise 4
 Bedienungshinweise 5 + 6
 Demontage 7 + 8
 Antennenanpassung 9
 Service Mode 9
 Programmierung der Geräteparameter 10 + 11
 FM-Abgleich 12 - 14

(F) Table des matières

Configuration de broches du bloc de connexion 15
 Représentation d'éléments d'alignement 2
 Représentation de points de mesure 3
 Pré-réglages / instructions de l'alignement 15
 Indications d'emploi 16 + 17
 Démontage 18 + 19
 Adaptation de l'antenne 20
 Mode de service 25
 Programmation de paramètres du poste 21 + 22
 Réglage FM 23 - 25

(GB) Table of Contents

Pin assignment of quick-fit connector 1
 Representation of alignment elements 2
 Representation of measuring points 3
 Pre-adjustments / alignment instructions 4
 Operating instructions 5 + 6
 Disassembly 7 + 8
 Antenna matching 9
 Service mode 9
 Programming of product parameters 10 + 11
 FM alignment 12 - 14

(E) Tabla de materias

Disposición de conectadores de la caja 15
 Representación de los elementos de ajuste 2
 Representación de los puntos de medida 3
 Pre-ajustes / instrucciones de alineamiento 15
 Indicaciones de manejo 16 + 17
 Desmontaje 18 + 19
 Adaptación de la antena 20
 Modo de servicio 25
 Programación de parámetros del aparato 21 + 22
 Alineamiento FM 23 - 25

Belegung des Anschlußkästchens





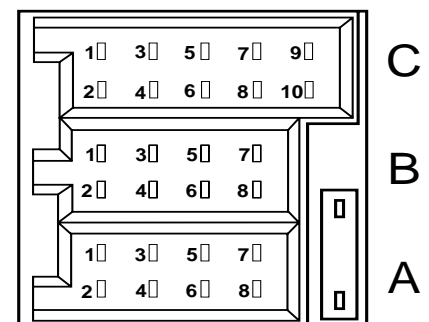

Pin assignment of quick-fit connector



A		B	
1	n.c.	1	n.c.
2	Telefon Mute / telephone mute	2	n.c.
3	n.c.	3	NF vorne rechts / AF right front
4	S-Kontakt / S-contact	4	NF Masse / AF ground
5	Automatik Antenne / Automatic antenna	5	NF vorne links / AF left front
6	Beleuchtung / Illumination	6	NF Masse / AF ground
7	Dauerplus / Permanent plus	7	n.c.
8	Masse / Ground	8	n.c.



Elektrische Bauteile
Composants électriques

Electric components
Piezas eléctricas

Position Position Position Posición	Bezeichnung Designation Dénomination Denominación	Bestell-Nr. Part no. No. de commande Número de pedido
D 40	BB 814	8 925 405 146
D 700	BZX 84/C10	8 925 421 063
D 1048	BAL 99	8 925 405 137
D 2000	S 3 G	8 925 405 023
D 2001	BAV 99	8 925 405 124
D 2002	BZX 84/C9V1	8 925 421 034
D 2009	BZX 84/C22	8 925 421 049
D 2030	BAL 99	8 925 405 137
D 2031	BZX 84/C5V1	8 925 421 062
D 2060	BAL 99	8 925 405 137
D 2061	BAL 99	8 925 405 137
D 2070	BAS 21	8 925 405 182
D 2078	BAL 99	8 925 405 137
D 2400	BZX 84/C4V3	8 925 421 046
		
F 51	10,7 MHz	8 948 417 028
F 152	10,7 MHz	8 948 417 027
		
H 850- H 859		8 638 800 492
		
H 1049	SLP 144B	8 945 405 908
H 1050- H 1064		8 925 405 190
H 1065	CLP / K 201	8 945 405 924
H 1071- H 1073		8 925 405 190
		
L 11		8 958 411 000
L 20		8 948 419 027
L 27		8 958 411 000
L 30		8 948 419 027
L 33		8 928 411 025
L 40		8 948 419 043
L 1000		8 948 411 054
L 2000		8 948 411 066
L 2002		8 948 411 054
L 2080		8 928 411 137
L 2081		8 928 411 038
		
Q 50		8 946 193 313
Q 53		8 946 193 313
Q 55		8 946 193 313
Q 301		8 946 193 097
Q 810		8 926 193 002
Q 2450		8 926 193 001
 		
R 174	100 kΩ	8 921 500 006
R 413	100 Ω	8 921 510 027
R 2080	PTC	8 921 351 009
S 1	DSP 301N	1 904 519 923

Position Position Position Posición	Bezeichnung Designation Dénomination Denominación	Bestell-Nr. Part no. No. de commande Número de pedido
 		
V 10	BC 858 B	8 925 705 038
V 20	BF 999	8 925 705 280
V 30	TDA 1575 T	8 925 900 339
V 152	TDA 1597 T	8 925 901 450
V 310	TDA 1591	8 925 900 977
V 360	BC 848 B	8 925 705 043
V 530	BC 848 B	8 925 705 043
V 531	BC 848 C	8 925 705 037
V 535	BC 640-16	8 925 707 300
V 541	BC 848 B	8 925 705 043
V 700	TDA 7326	8 925 900 904
V 701	BC 848 C	8 925 705 037
V 810	TMP 47C847F	8 925 904 133
V 811	BC 848 C	8 925 705 037
V 820	ST24C01AM6	8 925 902 067
V 860	BC 848 B	8 925 705 043
V 1050	BC 848 C	8 925 705 037
V 1065	BC 848 C	8 925 705 037
V 1066	BC 858 C	8 925 705 039
V 1110	RC 4558 DR	8 925 900 745
V 1540	BC 848 B	8 925 705 043
V 1560	BC 848 B	8 925 705 043
V 1590	AN 5733	8 945 903 705
V 1591	BC 858 B	8 925 705 038
V 1600	TDA 7376 B	8 945 903 286
V 1601	HCF 4066 M	8 925 900 019
V 1602	BC 848 C	8 925 705 037
V 1603	BC 848 C	8 925 705 037
V 1611	BC 848 C	8 925 705 037
V 1680	BC 818-25	8 925 705 041
V 2000	STP 20N	8 945 706 039
V 2001	BC 848 C	8 925 705 037
V 2002	BC 848 C	8 925 705 037
V 2003	BC 848 C	8 925 705 037
V 2005	MC 14093	8 925 901 045
V 2030	BC 848 C	8 925 705 037
V 2050	L 4916	8 945 900 450
V 2060	L 4949 N	8 925 900 348
V 2061	BC 848 C	8 925 705 037
V 2069	BC 858 B	8 925 705 038
V 2070	BC 848 C	8 925 705 037
V 2071	BC 848 C	8 925 705 037
V 2072	BC 858 C	8 925 705 039

Hinweis:

Handelsübliche Kondensatoren und Widerstände sind in der Ersatzteilliste nicht aufgeführt. Wir bitten Sie, diese Teile im Fachhandel zu beziehen.

Nota:

Des condensateurs et résistances commerciaux ne sont pas inclus dans la liste des pièces détachées. Veuillez acheter ces pièces chez votre spécialiste.

Note:

Capacitors and resistors usual in trade are not mentioned in the spare parts list. Kindly buy these parts from the specialized trade.

Nota:

No se indican en la lista de piezas de requestos los condensadores y los resistores de uso comercial. Les rogamos comprar esas piezas en el comercio especializado.

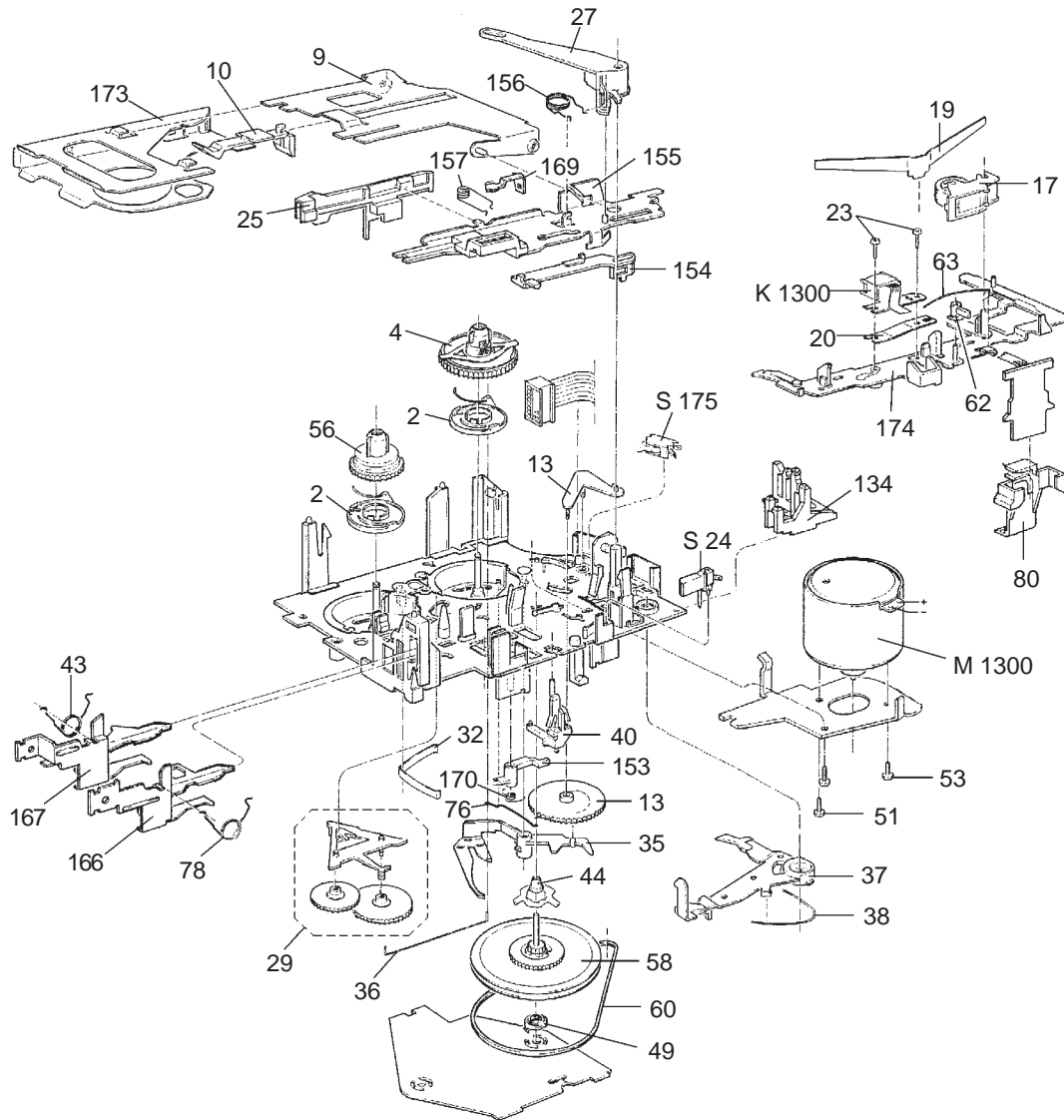

Position	Bestell-Nr.
Position	Part no.
Position	No. de commande
Posición	Número de pedido
LW 2	8 620 100 544
LW 4	8 626 600 480
LW 9	8 621 005 139
LW 10	8 621 300 558
LW 13	8 621 901 708
LW 17	8 626 600 481
LW 19	8 624 600 865
LW 20	8 624 600 866
LW 23	8 623 400 223
LW 25	8 621 300 559
LW 27	8 621 901 709
LW 29	8 621 005 140
LW 32	8 624 600 877
LW 35	8 621 901 710
LW 36	8 624 600 867
LW 37	8 621 901 711

Position	Bestell-Nr.
Position	Part no.
Position	No. de commande
Posición	Número de pedido
LW 38	8 624 600 868
LW 40	8 621 901 712
LW 43	8 624 600 869
LW 44	8 620 100 547
LW 45	8 626 600 486
LW 49	8 621 901 714
LW 51	8 623 400 224
LW 53	8 623 400 225
LW 56	8 626 600 487
LW 58	8 626 600 488
LW 60	8 624 700 420
LW 62	8 621 300 553
LW 63	8 624 600 871
LW 76	8 624 600 873
LW 78	8 624 600 872
LW 80	8 621 300 561

Position	Bestell-Nr.
Position	Part no.
Position	No. de commande
Posición	Número de pedido
LW 134	8 621 300 555
LW 153	8 621 300 556
LW 154	8 621 901 715
LW 155	8 621 901 716
LW 156	8 624 600 874
LW 157	8 624 600 875
LW 166	8 621 901 717
LW 167	8 621 901 718
LW 169	8 621 300 557
LW 170	8 624 600 876
LW 173	8 622 306 054
LW 174	8 621 300 560
K 1300	8 627 609 513
M 1300	8 627 205 770
S 24	8 622 002 101
S 175	8 622 002 100

Blaupunkt-Werke GmbH, Hildesheim

Änderungen vorbehalten! Nachdruck - auch auszugsweise - nur mit Quellenangabe gestattet

Gedruckt in Deutschland
Printed in Germany

Modification reserved! Reproduction - also by extract - only permitted with indication of sources used

Modification réservées! Reproduction - aussi en abrégé - permise seulement avec indication des sources utilisées

¡Modificaciones reservadas! Reproducción - también en parte - solamente permitida con indicación de las fuentes utilizadas

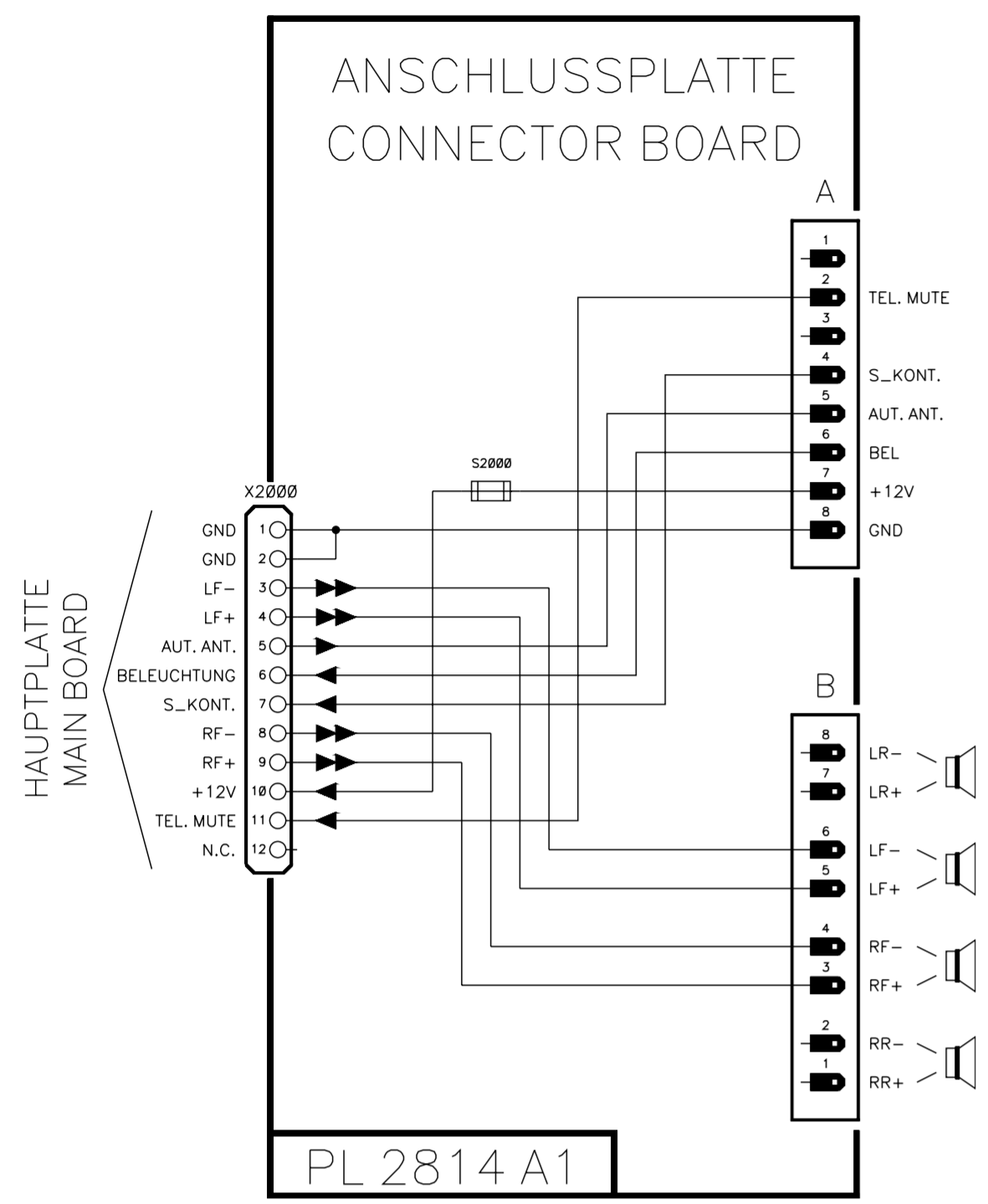

Schalterplatte
Key board
PL 0101 A02
Chip

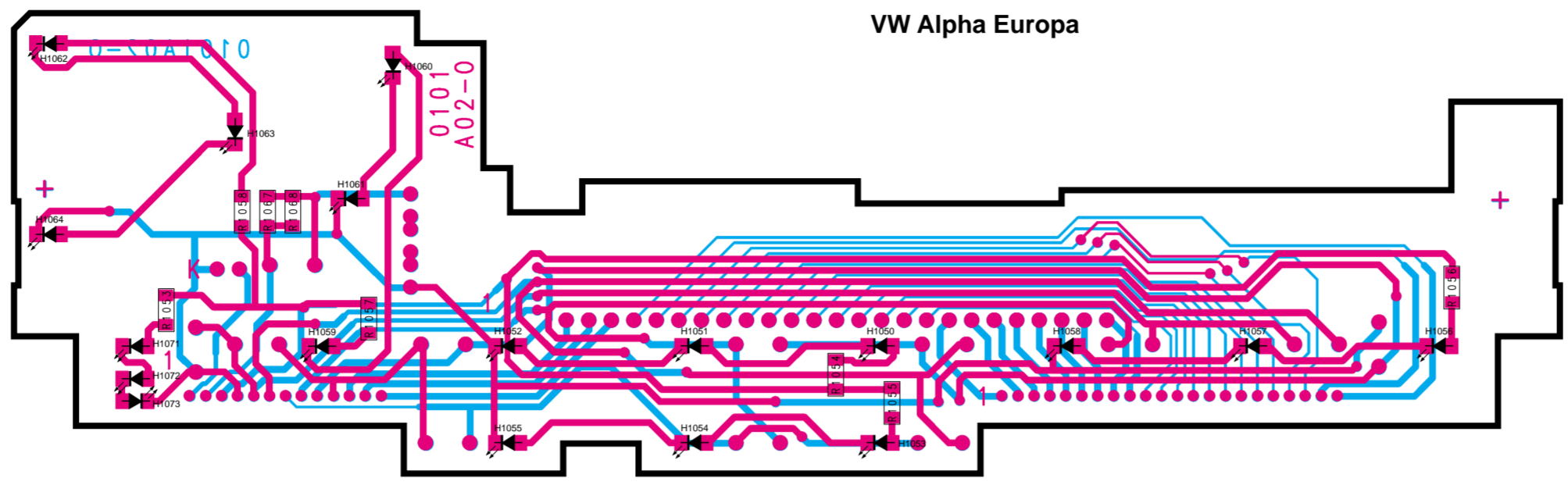

Schalterplatte
Key board
PL 0101 A02

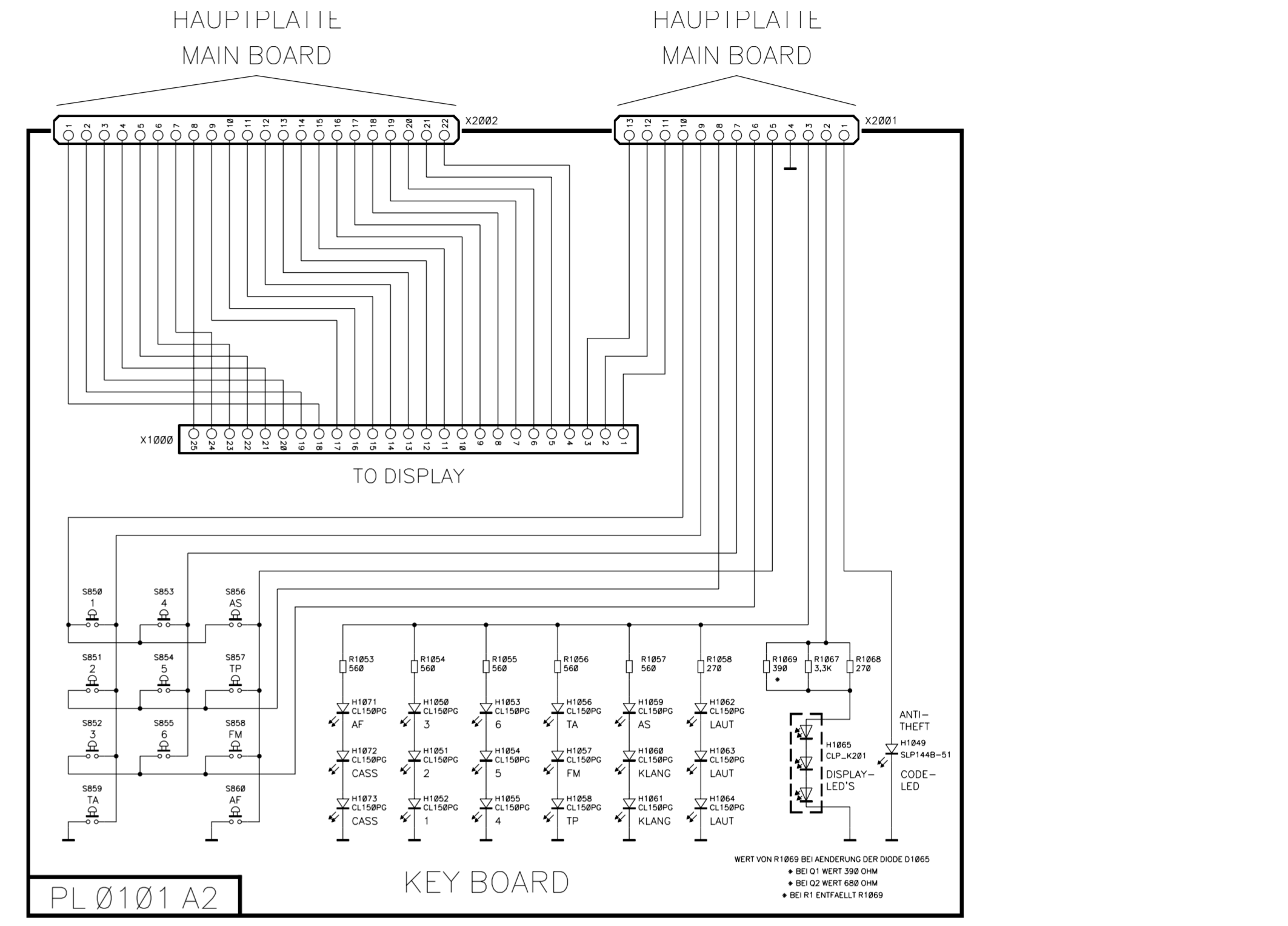
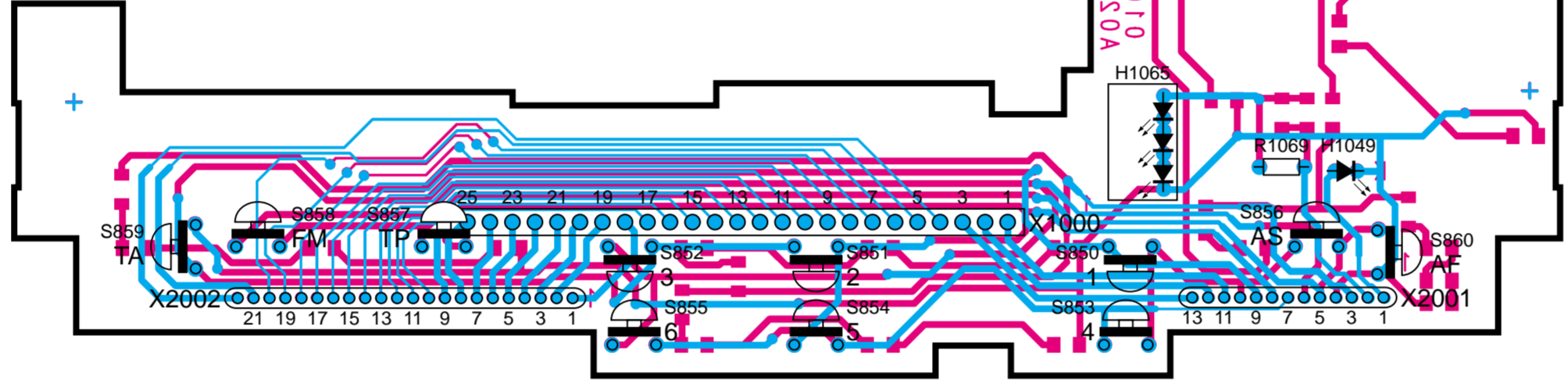

BLAUPUNKT AUTORADIO **VW Alpha Europa**
7 647 236 060

VW Alpha Europa Rot / Blau
7 647 238 060

8 622 401 392 BN-WG 10/97

Schaltbild • Circuit diagram • Schema du poste • Esquema del aparato

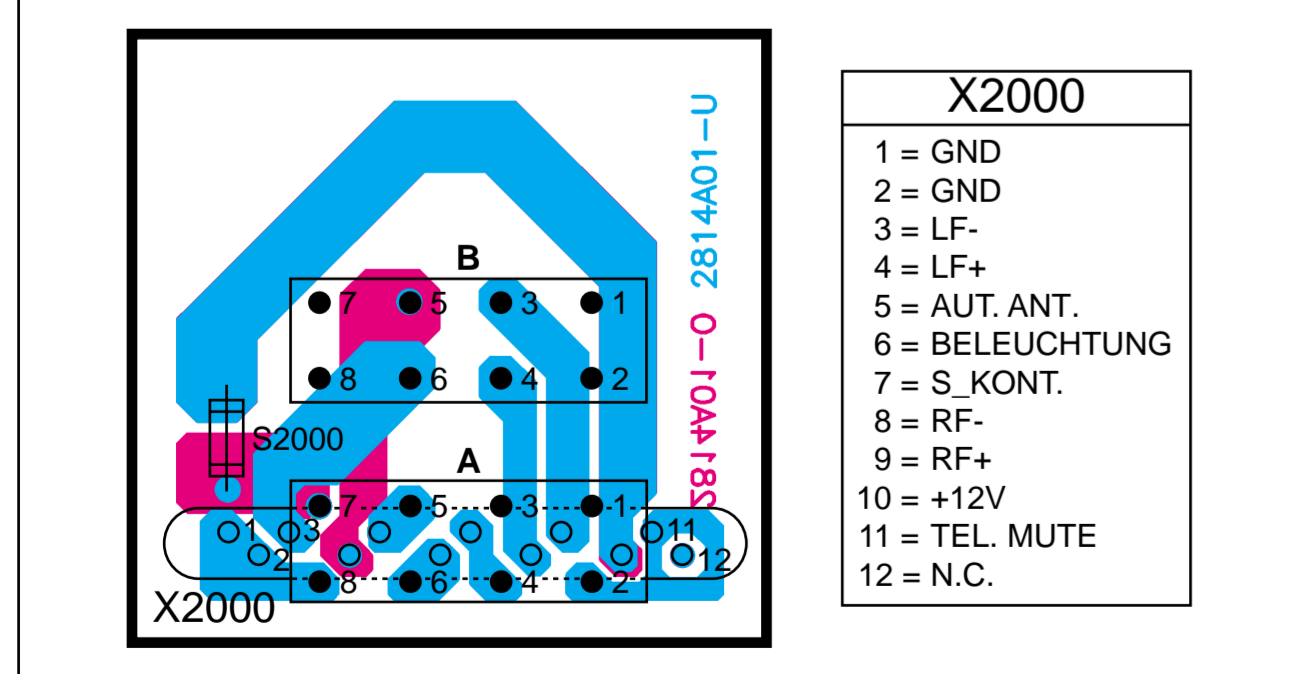

Schalterplatte
Key board
PL 0154 A03
Chip

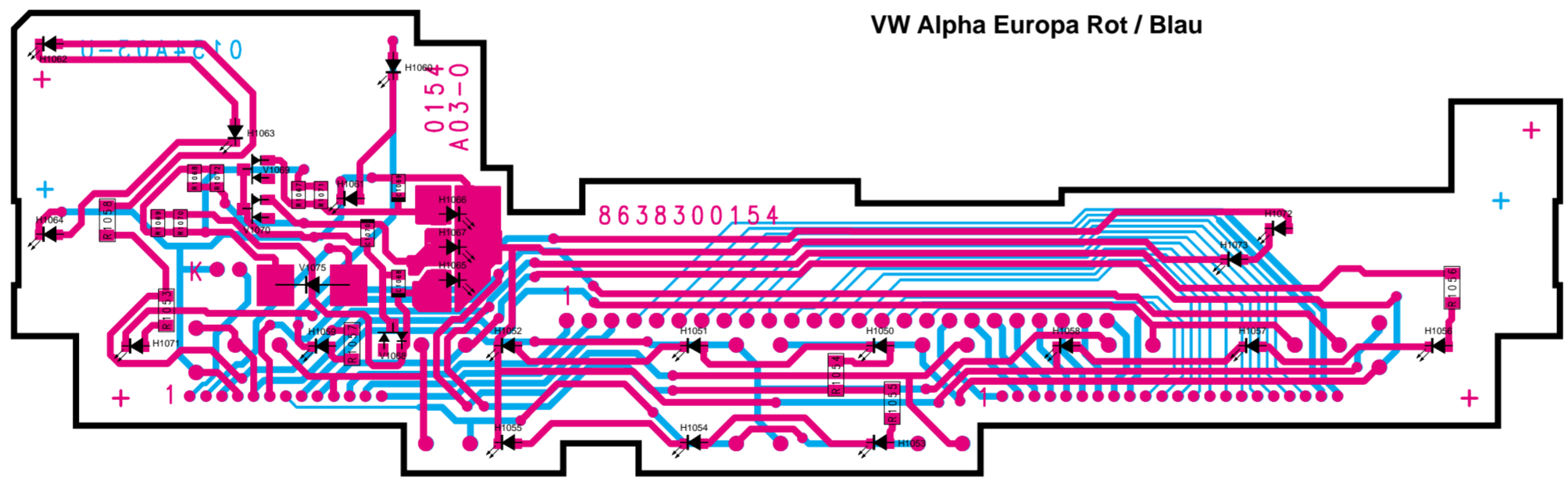

Schalterplatte
Key board
PL 0154 A03

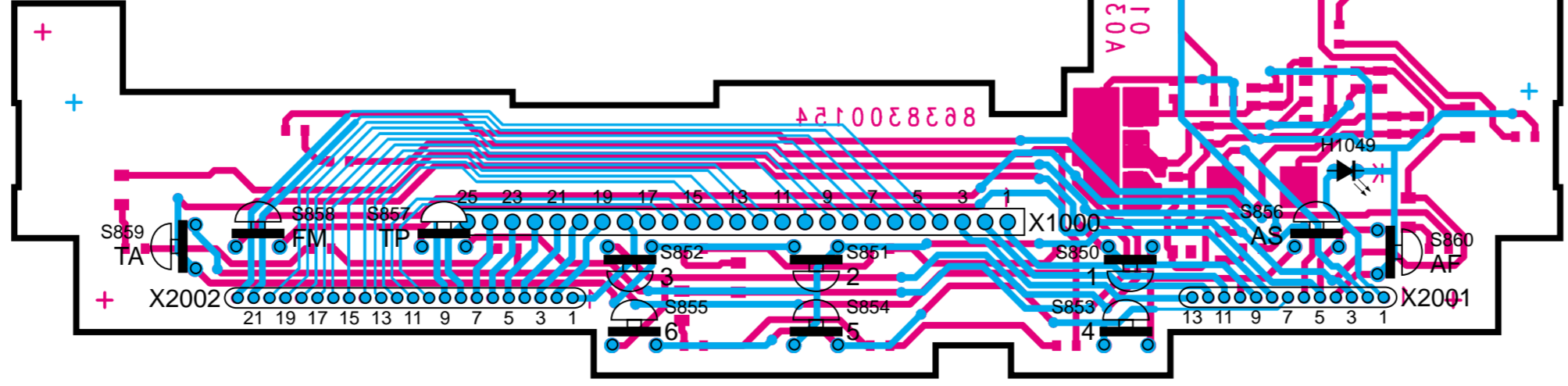

HAUPTPLATTE MAIN BOARD

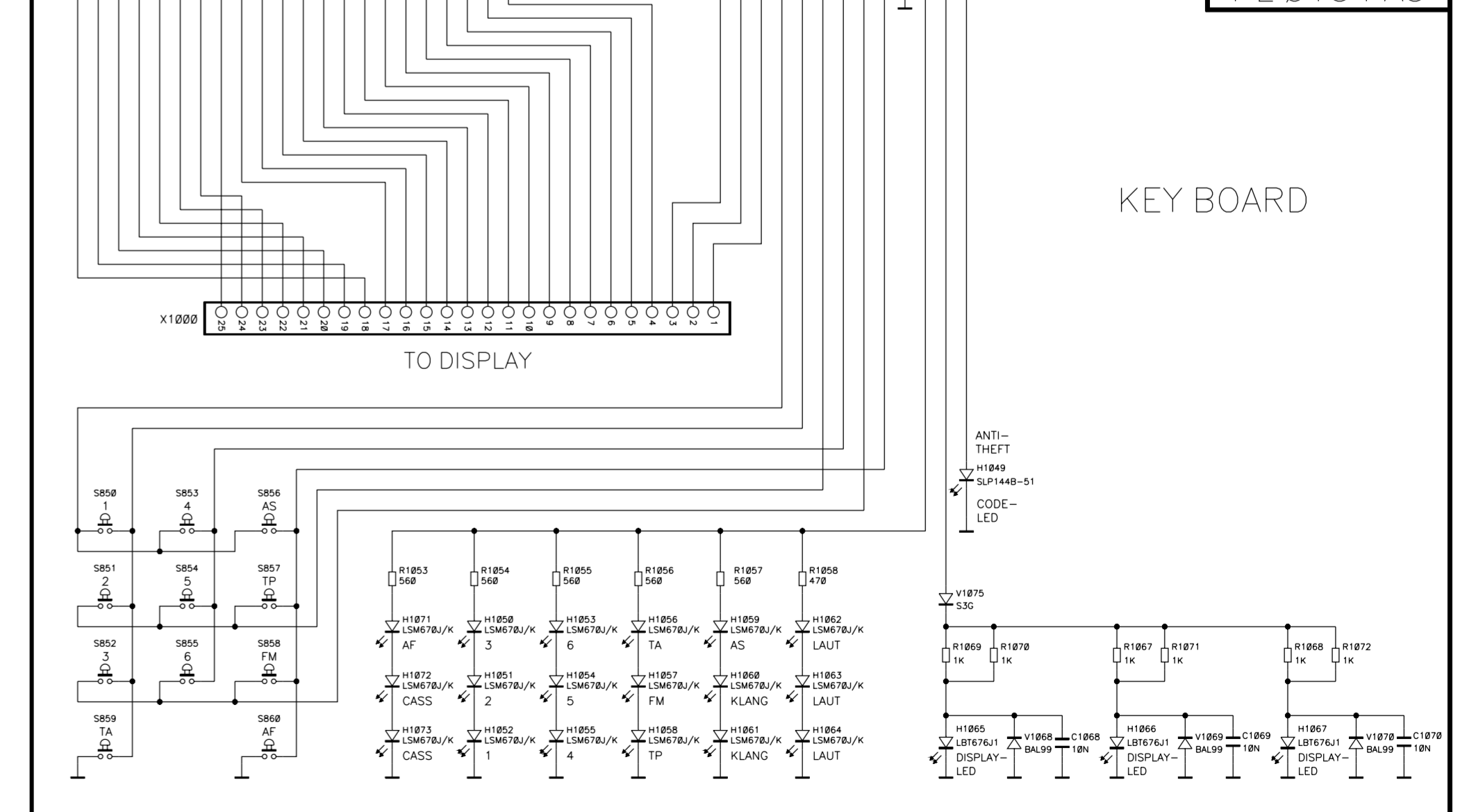

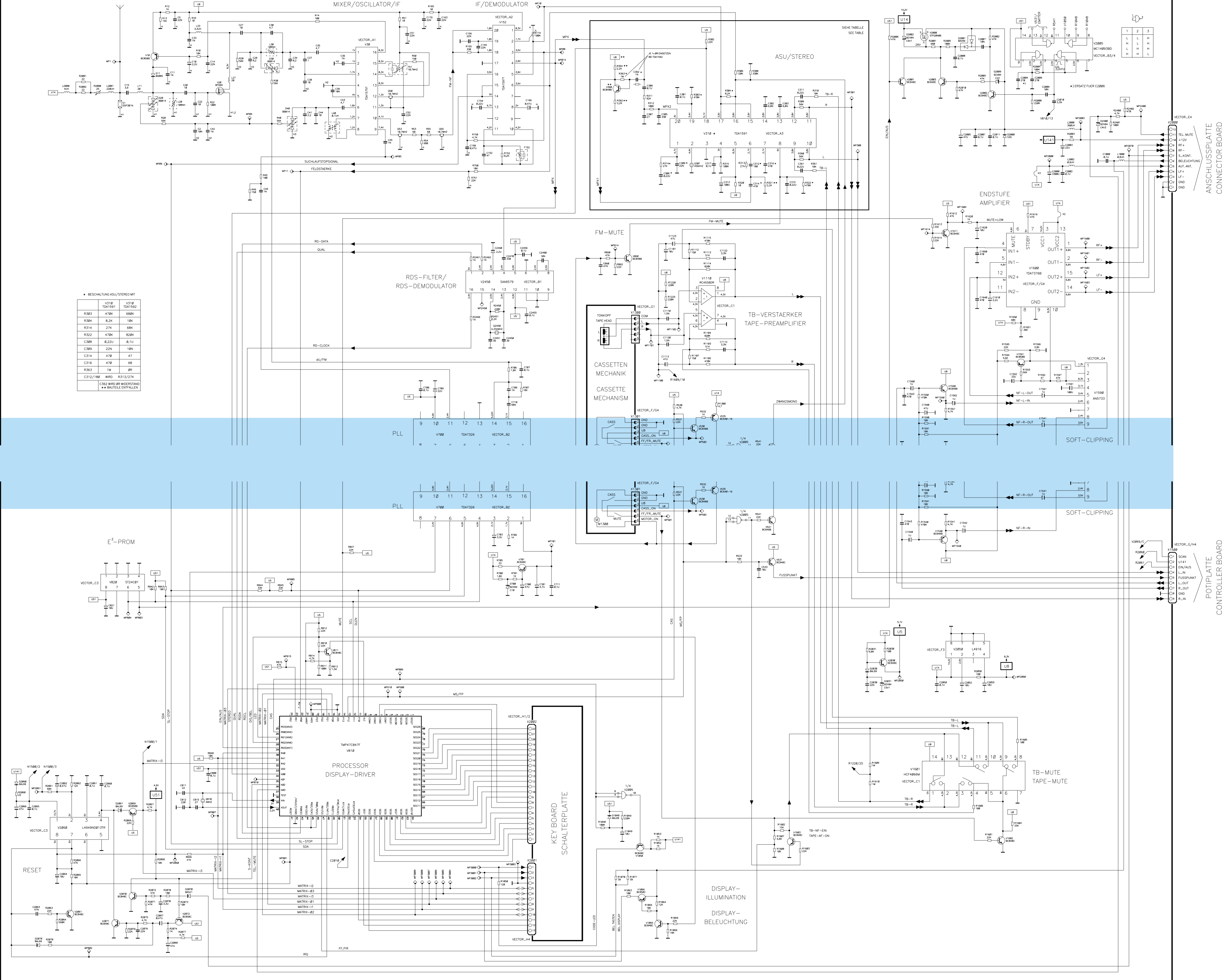

• BESCHALTUNG ASU/STEREO MIT

	V318 TDA1591	V318 TDA1592
R303	470K	680K
R304	6,2K	10K
R314	27K	68K
R322	470K	820K
C308	0,22µ	0,1µ
C309	22N	10N
C314	470	47
C316	470	68
R365	1M	BR
C312/188	MP83	R313/27K

□ 360 WIRD IM WIEDERSTAND
* BAUTEILE ENTFALLEN

Potiplatte
Controller board
PL 0102 A01

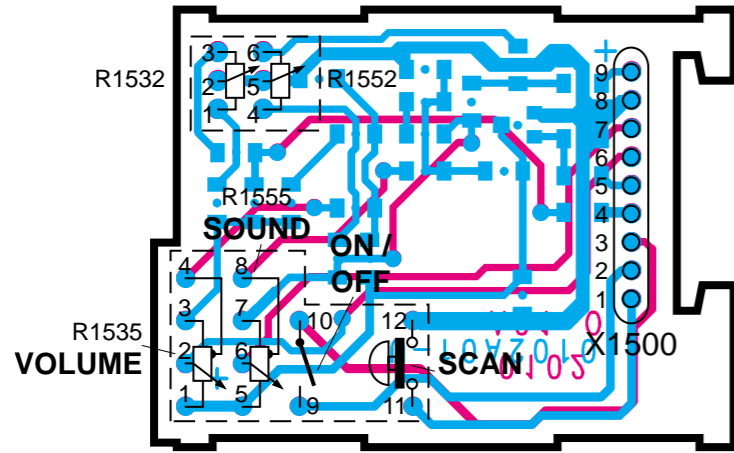

X1500	
1	= SCAN
2	= U141
3	= EIN/AUS
4	= L_IN
5	= FUSSPUNKT
6	= L_OUT
7	= R_OUT
8	= GND
9	= R_IN

Potiplatte
Controller board
PL 0102 A01
Chip

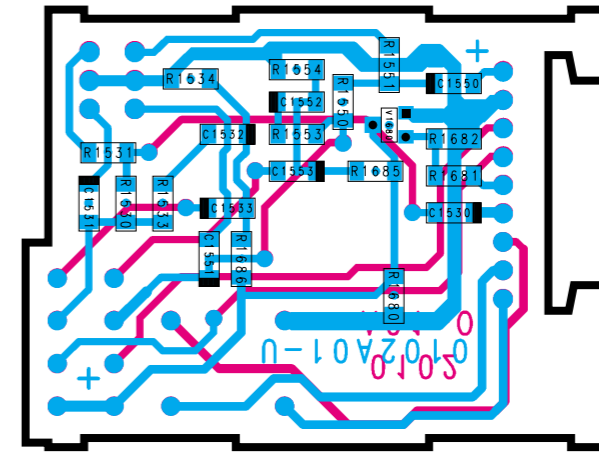
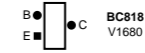

HAUPTPLATTE
MAIN BOARD

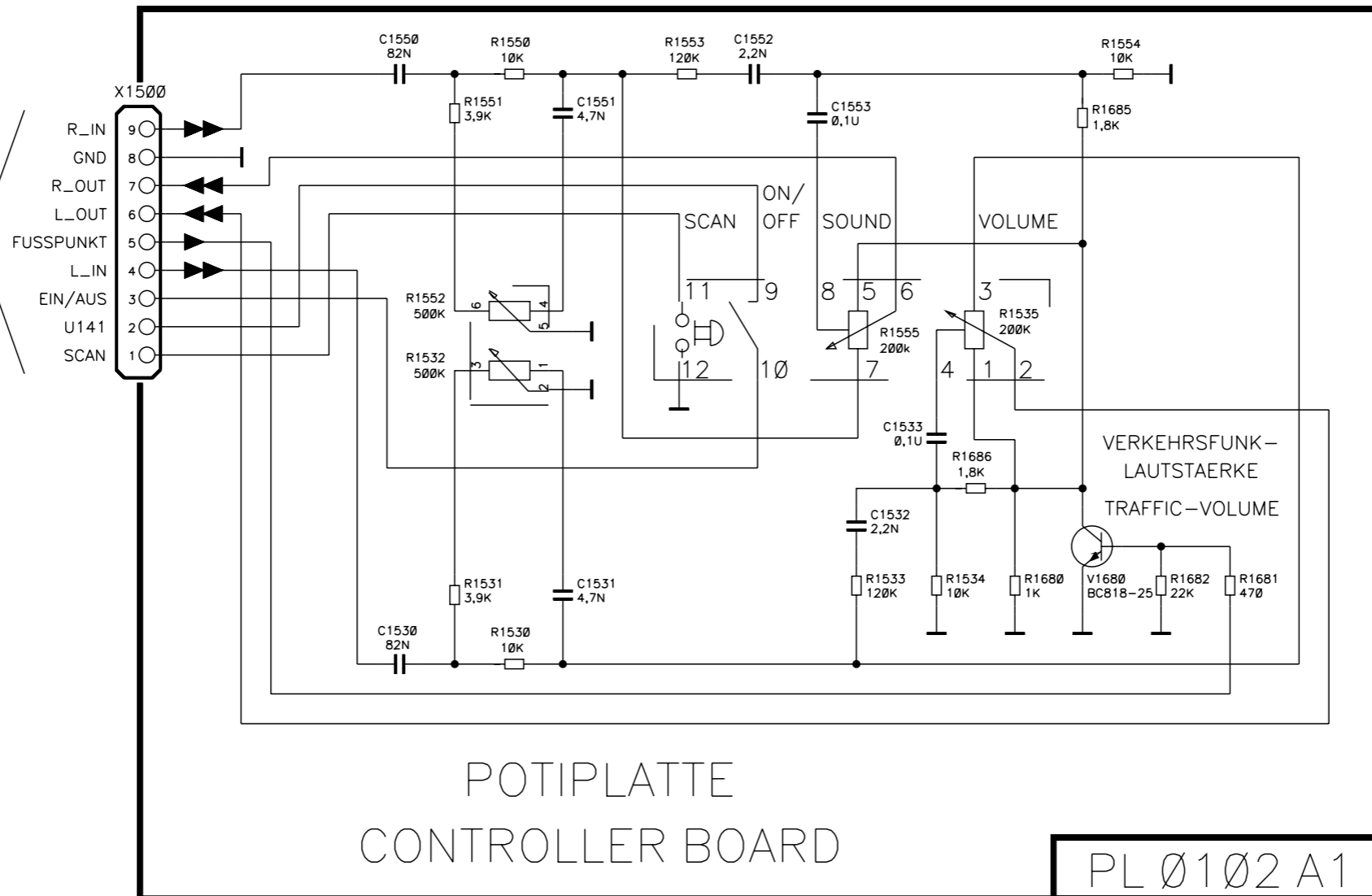

POTIPLATTE
CONTROLLER BOARD

PL 0102 A1